

US



Aristo[®]

U8₂



Instruction manual

1 SAFETY	5
2 INTRODUCTION	6
2.1 Control panel Aristo U82	6
2.1.1 Keys and knobs	6
2.2 Location	7
2.3 USB connection	7
2.3.1 Insert USB memory	8
2.4 First step – choice of language	8
2.5 Unit of length	9
2.6 Display	10
2.6.1 Symbols in the display	11
2.7 General information about settings	12
2.7.1 Setting of numerical values	12
2.7.2 Setting with given alternatives	12
2.7.3 Settings ON/OFF	12
2.7.4 QUIT and ENTER	12
3 MENUS	13
3.1 Main menu	13
3.1.1 Configuration menu	13
3.1.2 Tools menu	14
3.1.3 Weld data setting menu	14
3.1.4 Measure	15
3.1.5 Weld data memory meny	15
3.1.6 Fast mode menu	16
4 MIG/MAG WELDING	16
4.1 Settings in the weld data setting menu	17
4.1.1 MIG/MAG welding with short-/sprayarc	17
4.1.2 MIG/MAG welding with pulsing	18
4.1.3 MIG/MAG welding with SuperPulse, primary/secondary, short-/sprayarc/pulsing	19
4.1.4 MIG/MAG welding with QSet	20
4.2 Function explanations for settings	20
4.3 SuperPulse	25
4.3.1 Wire and gas combinations	25
4.3.2 Different pulsing methods	26
4.3.3 Wire feed unit	26
4.4 QSet	28
5 MMA WELDING	29
5.1 MMA welding DC	29
5.2 MMA welding AC	29
5.3 Function explanations for settings	30
6 GTAW WELDING	31
6.1 Settings in the weld data setting menu	31
6.1.1 GTAW welding without pulsing DC	31
6.1.2 GTAW welding with pulsing DC	31
6.1.3 GTAW welding without pulsing AC	32
6.2 Function explanations for settings	32
6.3 Other function explanations	36

7 ARC AIR GOUGING	37
7.1 Settings in the weld data setting menu	37
7.2 Function explanations	37
8 MEMORY MANAGEMENT	38
8.1 Control panel working method	38
8.2 Store	39
8.3 Recall	40
8.4 Delete	41
8.5 Copy	42
8.6 Edit	43
8.7 Name	45
9 CONFIGURATION MENU	46
9.1 Code lock	46
9.1.1 Lock code status	47
9.1.2 Specify/edit lock code	47
9.2 Remote controls	48
9.2.1 Forget override	48
9.2.2 Configuration for digital remote control unit	48
9.2.3 Configuration for analogue remote control unit	49
9.2.4 Scale on inputs	49
9.3 MIG/MAG defaults	50
9.3.1 Gun trigger mode (2-stroke/4-stroke)	50
9.3.2 4-stroke configuration	51
9.3.3 Soft key configuration	52
9.3.4 Voltage measurement in pulsing	53
9.3.5 AVC feeder	54
9.3.6 Release pulse	54
9.4 MMA defaults	54
9.5 Fast mode soft keys	54
9.6 Double start sources	55
9.7 Panel remote enable	55
9.8 Auto save mode	55
9.9 Trigger weld data switch	55
9.10 Multiple wire feeders	57
9.11 Quality functions	58
9.12 Maintenance	58
9.13 Measure value frequency	59
9.14 Register key	59

10 TOOLS	60
10.1 Error log	60
10.1.1 Units	61
10.1.2 Error code descriptions	61
10.2 Export/Import	64
10.3 File manager	65
10.3.1 Delete a file/folder	66
10.3.2 Rename a file/folder	66
10.3.3 Create new folder	66
10.3.4 Copy and paste files	67
10.4 Edit setting limits	67
10.5 Edit measure limits	68
10.6 Production statistics	69
10.7 Quality functions	70
10.7.1 Store quality data	71
10.8 User defined synergic data	72
10.8.1 Specify voltage/wire co-ordinates	72
10.8.2 Specify valid wire/gas combination	73
10.8.3 Create your own wire/gas alternative	74
10.9 Calendar	75
10.10 User accounts	75
10.11 Unit information	76
11 ORDERING SPARE PARTS	76
MENU STRUCTURE	77
WIRE AND GAS DIMENSIONS	83
ORDERING NUMBER	86
ACCESSORIES	87

1 SAFETY

NOTE! This unit is tested by ESAB in a general set-up. The responsibility for safety and function, of the specific set-up, lies with the integrator.

Users of ESAB welding equipment have the ultimate responsibility for ensuring that anyone who works on or near the equipment observes all the relevant safety precautions. Safety precautions must meet the requirements that apply to this type of welding equipment. The following recommendations should be observed in addition to the standard regulations that apply to the workplace.

All work must be carried out by trained personnel well-acquainted with the operation of the welding equipment. Incorrect operation of the equipment may lead to hazardous situations which can result in injury to the operator and damage to the equipment.

1. Anyone who uses the welding equipment must be familiar with:
 - its operation
 - location of emergency stops
 - its function
 - relevant safety precautions
 - welding
2. The operator must ensure that:
 - no unauthorized person is stationed within the working area of the equipment when it is started up.
 - no-one is unprotected when the arc is struck
3. The workplace must:
 - be suitable for the purpose
 - be free from drafts
4. Personal safety equipment
 - Always wear recommended personal safety equipment, such as safety glasses, flame-proof clothing, safety gloves. **Note!** *Do not use safety gloves when replacing wire.*
 - Do not wear loose-fitting items, such as scarves, bracelets, rings, etc., which could become trapped or cause burns.
5. General precautions
 - Make sure the ground cable is connected securely.
 - Work on high voltage equipment **may only be carried out by a qualified electrician.**
 - Appropriate fire extinguishing equipment must be clearly marked and close at hand.
 - Lubrication and maintenance must **not** be carried out on the equipment during operation.

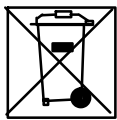

Do not dispose of electrical equipment together with normal waste!

In observance of European Directive 2002/96/EC on Waste Electrical and Electronic Equipment and its implementation in accordance with national law, electrical equipment that has reached the end of its life must be collected separately and returned to an environmentally compatible recycling facility. As the owner of the equipment, you should get information on approved collection systems from our local representative.

By applying this European Directive you will improve the environment and human health!

2 INTRODUCTION

To benefit as much as possible from your welding equipment, we recommend that you read this instruction manual.

For general information about operation, see the instruction manuals for the power source and the wire feed unit.

The text presented in the display is available in the following languages: English, Swedish, Finnish, Norwegian, Danish, German, French, Italian, Dutch, Spanish, Portuguese, Hungarian, Polish, American, Czech and Chinese.

NOTE! Differences in the panel function may occur, depending on which product is installed.

2.1 Control panel Aristo U8₂

The control panel is supplied with a mounting bracket with screws and an English instruction manual. A 1.2 m cable is mounted on to the panel. A USB memory and an extension cable are available as accessories, see page 87.

Instruction manuals in other languages can be downloaded from the website, www.esab.com.

1 Place for USB memory

2 Knob for moving cursor

3 Display

4 Soft keys 

5 Menu 

6 Enter 

7 Knob for increasing or decreasing set values and setting the voltage, #

8 Knob for increasing or decreasing set values and setting the wire feed speed, *



2.1.1 Keys and knobs

Soft keys (4)

The five keys in a row under the display have varying functions. These are “soft” keys, i.e. they can have different functions depending on which menu you are currently working in. The current function for these keys can be seen from the text in the bottom row of the display.

When the function is active, this is indicated by

the key turning white: 



Menu key (5)

Using the MENU key  always takes you back to the main menu:

MIG/MAG	
PROCESS	MIG/MAG
METHOD	SHORT/SPRAY
WIRE TYPE	Fe
SHIELDING GAS	Ar+8%CO2
WIRE DIAMETER	1/16"
CONFIGURATION ▶	
TOOLS ▶	

SET	MEASURE	MEMORY	FAST MODE
-----	---------	--------	-----------



Enter key (6)

Using the ENTER key  confirms a selection.

Cursor knob (2)

Using the left-hand knob moves the cursor to different rows in the display.

Plus/minus knobs (7, 8)

The right-hand knobs increase or decrease the value of a setting. To the side of the knobs there is a symbol, a square  or a star . Most numerical settings can be adjusted with either knob, although certain settings have to be made with a particular knob.

2.2 Location

On the reverse of the control panel there is a fold-out stand that enables you to put the panel down and still view the display in an upright position. The stand also acts as a mounting device, enabling the control panel to be hung on the wire feed unit.



2.3 USB connection

External USB memories can be used to transfer programs to and from the control panel. See more in chapter [10.2](#).

The files that are produced in the control panel are stored as xml files. The USB memory must be formatted as FAT 32 in order to work.

During normal use there is no risk of “viruses” being able to infect the equipment. To eliminate this risk entirely, we recommend that the memory that is used together with this equipment not be used for any other purpose.

Certain USB memories may not work with this equipment. We recommend using USB memories from a reputable supplier. *ESAB assumes no responsibility for any damage caused as a consequence of the incorrect use of a USB memory.*

2.3.1 Insert USB memory

Proceed as follows:

- Turn off the power source's main switch.
- Open the cover on the left-hand end of the control panel.
- Insert the USB memory in the USB connector.
- Close the cover.
- Turn on the power source's main switch.



2.4 First step – choice of language

This menu appears in the display the first time you start up the equipment.

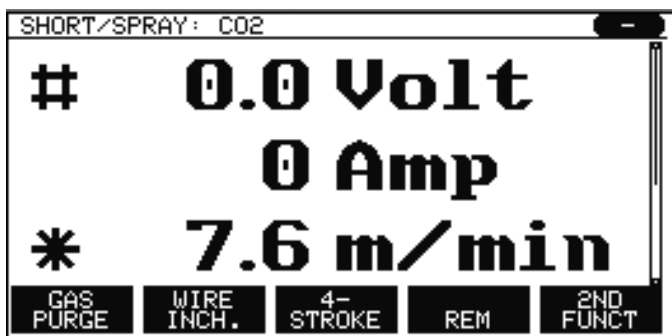

The control panel is set to English on delivery. To select your language, proceed as follows.

Press MENU  to come to the main menu.

Using the left-hand knob, position the cursor on the CONFIGURATION row

MIG/MAG	
PROCESS	MIG/MAG
METHOD	SHORT/SPRAY
WIRE TYPE	Fe
SHIELDING GAS	Ar+8%CO2
WIRE DIAMETER	1/16"
CONFIGURATION ▶	
TOOLS ▶	
SET	MEASURE
MEMORY	FAST MODE

Press ENTER .

Position the cursor on the LANGUAGE row. Press ENTER to bring up a list of the languages that are available in the control panel.

CONFIGURATION	
LANGUAGE	ENGLISH
CODE LOCK	▶
REMOTE CONTROLS	▶
MIG/MAG DEFAULTS	▶
MMA DEFAULTS	▶
FAST MODE SOFT KEYS	▶
DOUBLE START SOURCES	OFF
PANEL REMOTE ENABLE	OFF
AUTO SAVE MODE	OFF
TRIGGER WELDDATA SWITCH	▶
QUIT	

Position the cursor on the row for your language and press ENTER.

NORSK
POLSKI
PORTUGUES
SUOMI
SVENSKA
CHINESE

2.5 Unit of length

The control panel is set to metric measurement on delivery. To select another measurement, proceed as follows:

Press Menu  to access the main menu.

Using the left-hand knob, position the cursor on the CONFIGURATION row.

MIG/MAG	
PROCESS	MIG/MAG
METHOD	SHORT/SPRAY
WIRE TYPE	Fe
SHIELDING GAS	Ar+8%CO2
WIRE DIAMETER	1/16"
CONFIGURATION	▶
TOOLS	▶
SET	MEASURE
MEMORY	FAST MODE

Press ENTER  to confirm the selection.

Position the cursor on the UNIT OF LENGTH row. Press ENTER to bring up a list of the measurements that are available in the control panel.

CONFIGURATION	
TRIGGER WELDDATA SWITCH ▶	
MULTIPLE WIRE FEEDERS ▶	
QUALITY FUNCTIONS ▶	
MAINTENANCE ▶	
UNIT OF LENGTH	METRIC
MEASURE VALUE FREQUENCY	1 Hz
REGISTER KEY ▶	
QUIT	

Position the cursor on the row for correct measurement and press ENTER.

METRIC INCH.

2.6 Display

MIG/MAG	
PROCESS	MIG/MAG
METHOD	SHORT/SPRAY
WIRE TYPE	Fe
SHIELDING GAS	Ar+8%CO2
WIRE DIAMETER	1/16"
CONFIGURATION ▶	
TOOLS ▶	
SET	MEASURE
MEMORY	FAST MODE

The cursor

The control panel's cursor is presented as a shaded field around the text, with the selected text turning white. The selection is displayed in the instruction manual with bold text.

Arrows and scroll bars

Where there is more information behind a row, this is indicated with a black arrow behind the text. A scroll bar is presented to the right of the display if there are more rows in the list:

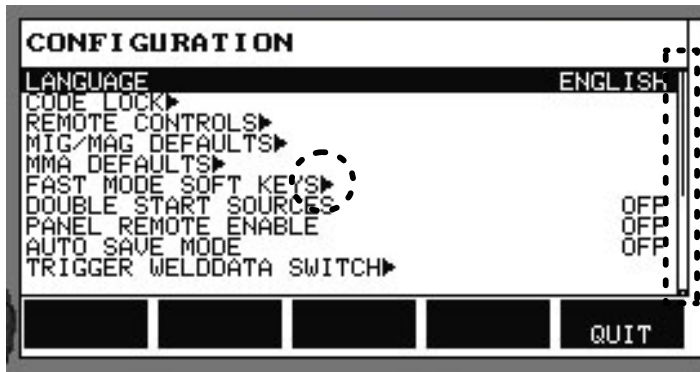

Text boxes

At the bottom of the display are five boxes containing text that describes the current function of the five keys directly below the boxes.

Energy saving mode

To increase the life of the background lighting, it is switched off after three minutes of no activity.

2.6.1 Symbols in the display

The image shows the main display with the following information: 'MIG/MAG PULSE: 1.0 mm', '1.0', and '1.0'. The main display shows '# 0.0 Volt', '0 Amp', and '196 in/min'. At the bottom, there are five buttons: 'GAS PURGE', 'WIRE INCH.', '4-STROKE', 'REM', and '2ND FUNCT'. Callouts A through G point to various symbols and indicators: A points to the top bar, B points to the '1.0' value, C points to a fault indicator, D points to a recalled memory position number, E points to the plus/minus knob marked with '#', F points to the measured motor current '0 Amp', and G points to the plus/minus knob marked with '*'.

- A The selected weld data set
- B The selected wire feed unit
- C A fault has occurred. See chapter 15
- D Recalled memory position number
- E Select the plus/minus knob marked with # to increase or decrease a parameter value.
- F Measured motor current
- G Select the plus/minus knob marked with * to increase or decrease a parameter value.

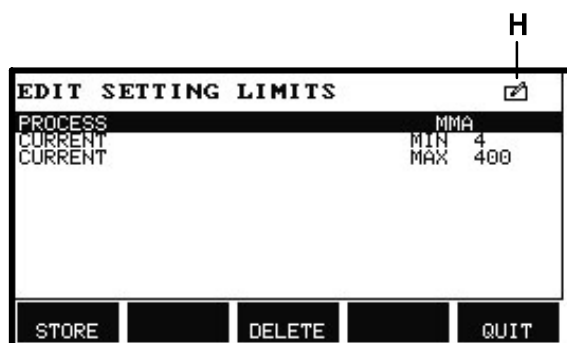

2.7 General information about settings

There are three main types of setting:

- Setting of numerical values
- Setting with given alternatives
- Setting of ON/OFF mode

2.7.1 Setting of numerical values

When setting a numerical value, one of the two plus/minus knobs is used to increase or decrease a given value. A number of values can also be altered from the remote control unit.

2.7.2 Setting with given alternatives

Some settings are made by selecting an alternative from a list. Such a list might look like this:

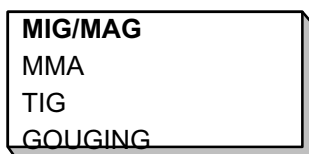

Here the cursor is placed on the row for MIG/MAG. By pressing ENTER in this position, the MIG/MAG alternative is selected. If you want to choose another alternative instead, position the cursor on the correct row by stepping up or down with the left knob. Then press ENTER. If you want to exit the list without making a selection, press QUIT.

2.7.3 Settings ON/OFF

For some functions, it is possible to set the values ON and OFF. The synergy function during MIG/MAG and MMA welding is an example of such a function. The ON or OFF settings can be selected from a list of alternatives as described above.

2.7.4 QUIT and ENTER

The “soft” key farthest to the right is used primarily for QUIT, although it is occasionally used for other functions.

- Pressing QUIT entails moving back to the previous menu or screen.

The  key is called ENTER in this manual.

- Pressing ENTER entails the execution of a selected choice in a menu or a list.

3 MENUS

The control panel uses several different menus. The menus are the Main, Configuration, Tools, Weld data setting, Measure, Weld data memory and Fast mode menus. The menu structures are displayed from the page 77. During start-up, a start-up screen containing information about the current program version is also displayed briefly.



Start-up screen

3.1 Main menu

In the MAIN MENU, you can change welding process, welding method, wire type, etc. From this menu you can proceed to all other sub-menus.

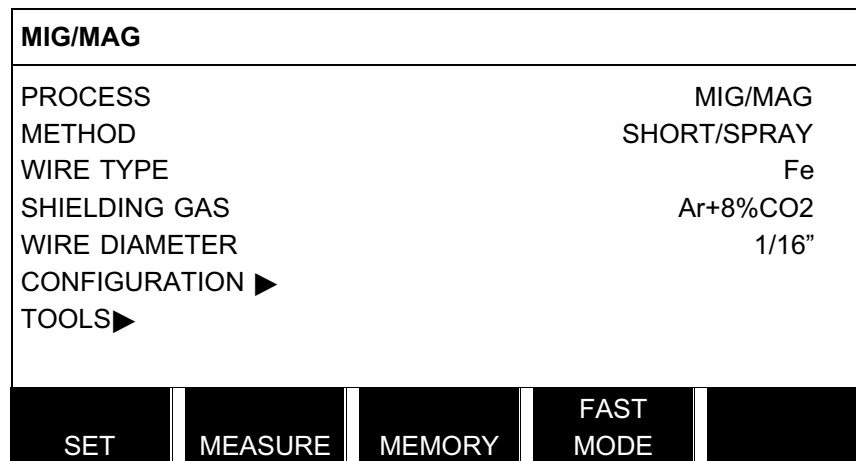

3.1.1 Configuration menu

In the CONFIGURATION menu you can change language, alter other basic settings, unit of measurement, etc.

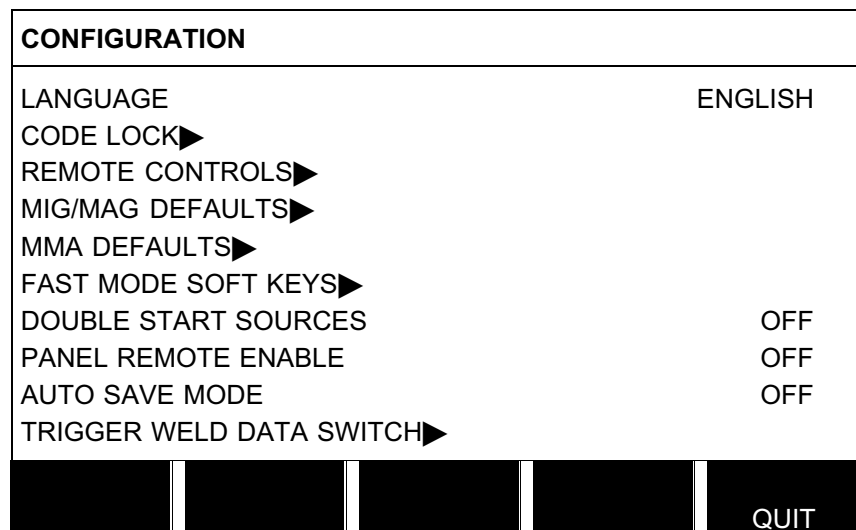

3.1.2 Tools menu

In the TOOLS menu you can transfer files, view quality and production statistics, error logs, etc.

TOOLS	
ERROR LOG▶	
EXPORT/IMPORT▶	
FILE MANAGER▶	
SETTING LIMIT EDITOR▶	
MEASURE LIMIT EDITOR▶	
PRODUCTION STATISTICS▶	
QUALITY FUNCTIONS▶	
USER DEFINED SYNERGIC DATA▶	
CALENDAR▶	
USER ACCOUNTS▶	
	QUIT

3.1.3 Weld data setting menu

SET

In the WELD DATA SETTING menu you can alter various welding parameters. The menu has different appearances depending on which welding process is selected. The example shows MIG/MAG welding with short-/sprayarc.

WELD DATA SETTING	
VOLTAGE	28.2 (+3.5) V
WIRE SPEED	236IN/MIN
INDUCTANCE	80%
SYNERGIC MODE	ON
START DATA▶	
STOP DATA▶	
SETTING LIMITS▶	
MEASURE LIMITS▶	
SPOT WELDING▶	
EDIT DESCRIPTION▶	
CRATER FILL	HOT START
	4-STROKE
	QUIT

3.1.4 Measure **MEASURE**

In MEASURE, you can view measured values for various welding parameters while welding is in progress.

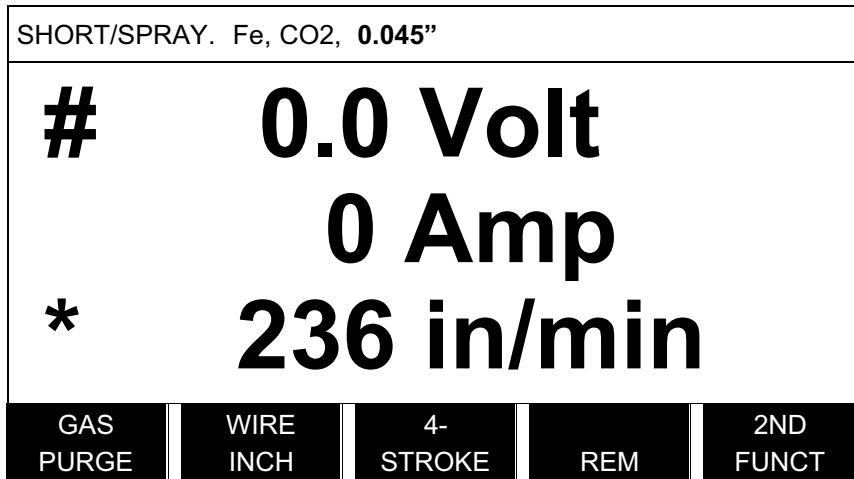

You can change the value of certain parameters in the Measure screen. Which parameters these are depends on which welding process is set. The parameter values that can be adjusted are always marked with # or *.

The measured values remain in the display even after welding has been completed. You can move to different menus without losing the measurement values. If the set value is altered when welding is not in progress, the measurement value is changed to zero in order to avoid confusion.

TIP:

When pulsing, you can select whether the voltage value is to be displayed as an average value or a peak value. This setting can be adjusted under MIG/MAG defaults, see chapter 9.3.

3.1.5 Weld data memory meny **MEMORY**

In the WELD DATA MEMORY menu you can store, recall, delete and copy various set weld data. The weld data sets can be stored in 255 different memory positions.

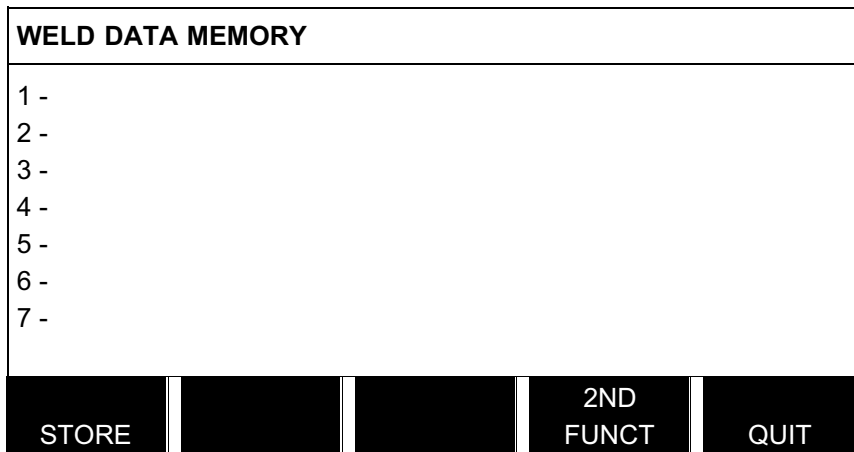

For further information, see the chapter 8 “Memory management”.

3.1.6 Fast mode menu **FAST MODE**

In the FAST MODE menu, you can “link” soft keys to weld data memory positions. These settings are carried out in the Configuration menu. The number of the selected memory position is displayed in the top right corner.

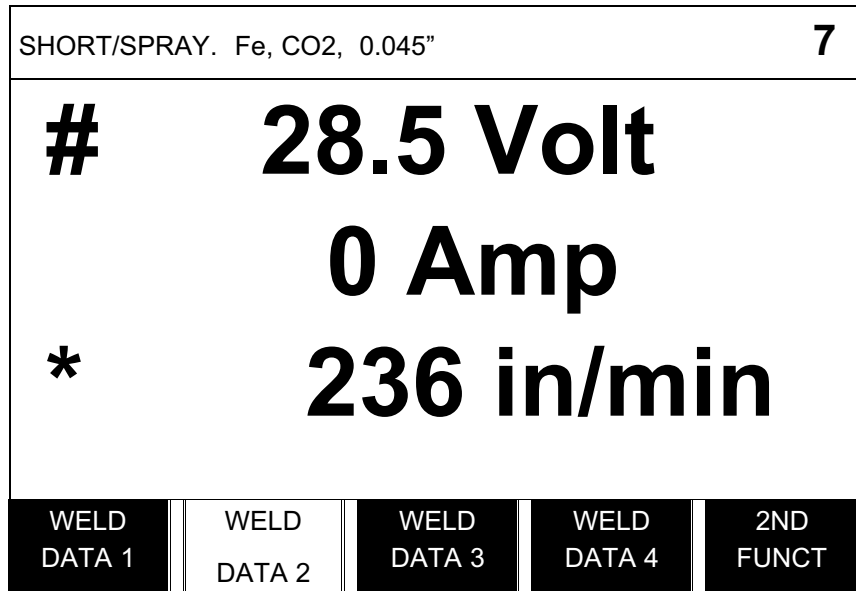

For further information, see the chapter 9.5 “Fast mode soft keys”.

4 MIG/MAG WELDING

Main menu → Process

MIG/MAG welding melts a continuously supplied filler wire, with the weld pool being protected by shielding gas.

Pulsing is used to influence the transfer of the droplets from the arc so that it remains stable and spatter-free, even with low weld data.

The table on page 83 shows the wire diameters that can be selected for **MIG/MAG** welding with **SHORT-/SPRAYARC**.

The table on page 83 shows the wire diameters that can be selected for **MIG/MAG** welding with **PULSING**.

When the MIG/MAG process is selected, you can choose between four methods by selecting Method with the left-hand knob and then pressing ENTER. Choose between short-/sprayarc, pulse, superpulse or QSet and then press ENTER again.

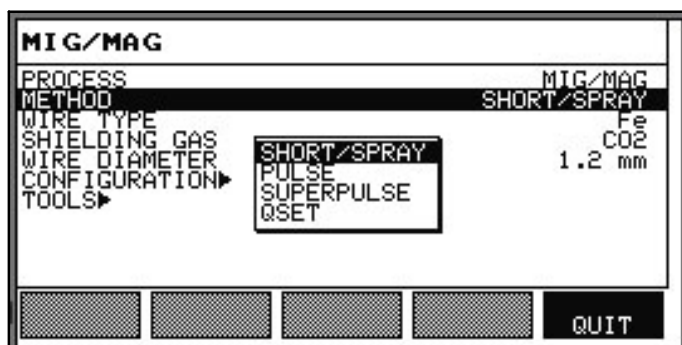

4.1 Settings in the weld data setting menu

4.1.1 MIG/MAG welding with short-/sprayarc.

Settings	Setting range	In steps of	Synergy dependent	Adjustable in synergy
Voltage	8 - 60 V	0.25 V (displayed with one decimal)	x	x
Wire feed speed**	31 - 1183 in /min	4 in/min		x
Inductance	0 - 100%	1%	x	x
Regulator type	1 - 12	1	x	-
Synergy*	OFF or ON	-	-	-
Gas pre-flow	0.1 - 25 s	0.1 s		x
Creep start	OFF or ON	-		x
“Hot start”	OFF or ON	-		x
“Hot start” time	0 - 10 s	0.1 s		x
“Hot start” wire feed	Complete wire feed range	4 in/min		x
“Touch sense”	0 - 20 A			
Crater filling	OFF or ON	-		x
Crater filling time	0 - 10 s	0.1 s		x
Final crater filling wire feed	59 in/min at current wire feed speed	4 in/min		x
Final crater filling voltage	8 - 24.7 V		x	
“Release pulse”***	OFF or ON			
Burnback time	0 - 1 s	0.01 s		x
Gas post-flow	0.1 - 25 s	0.1 s		x
Setting limits	1 - 50	-	-	-
Measure limits	1 - 50	-	-	-
Spot welding	OFF or ON	-		x
Spot welding time	0 - 25 s	0.1 s		x

*) The synergic line on delivery: solid wire (Fe), shielding gas CO₂ with wire 0.045 inch.

**) The setting range is dependent on the wire feed unit used.

***) Adjusted in the configuration menu MIG/MAG defaults.



4.1.2 MIG/MAG welding with pulsing

Settings	Setting range	In steps of	Synergy dependent	Adjustable in synergy
Voltage	10 - 50 V	0.25 V (displayed with one decimal)	x	x
Wire feed speed*	31 - 1183 in /min	4 in/min		x
Pulse current**	100 - 650 A	4 A	x	
Pulse time	1.7 - 25.5 ms	0.1 ms	x	
Pulse frequency	16 - 312 Hz	2 Hz	x	
Background current	4 - 300 A	1 A	x	
Slope	1 - 9	1	x	
Synergy***	OFF or ON	-	-	-
Ka	0 - 100%	1%	x	
Ki	0 - 100%	1%	x	
Gas pre-flow	0.1 - 25 s	0.1 s		x
Creep start	OFF or ON	-		x
“Hot start”	OFF or ON	-		x
“Hot start” time	0 - 10 s	0.1 s		x
“Hot start” wire feed	Complete wire feed range	4 in/min		x
“Touch sense”	0 - 20 A			
Crater filling (pulsed/not pulsed)	OFF or ON	-		x
Crater filling time	0 - 10 s	0.1 s		x
Final crater filling wire feed	59 in/min at current wire feed speed	4 in/min		x
Final crater filling voltage	8 - 33.2 V		x	
Final pulse current	100 - max A		x	
Final background current	12 - 50 A		x	
Final frequency	20 - 270 Hz		x	
“Release pulse”****	OFF or ON			
Burnback time	0 - 1 s	0.01 s		x
Gas post-flow	0.1 - 25 s	0.1 s		x
Setting limits	1 - 50	-	-	-
Measure limits	1 - 50	-	-	-
Spot welding	OFF or ON	-		x
Spot welding time	0 - 25 s	0.1 s		x

*) The setting range is dependent on the wire feed unit used.

**) Minimal background current and pulse current are dependent on which machine type is used.

***) The synergic line on delivery: solid wire (Fe), shielding gas CO₂ with wire 0.045 inch.

****) Adjusted in the configuration menu MIG/MAG defaults.

4.1.3 MIG/MAG welding with SuperPulse, primary/secondary, short-/sprayarc/pulsing

Main menu → Process → Method → Phase → Method

Settings	Setting range	In steps of	Synergy dependent	Adjustable in synergy
Phase	Primary or Secondary	-		X
Method	Short-/sprayarc or pulsing	-		X
Voltage	10 - 50 V	0,25 V (displayed with 1 decimal)	X	X
Wire feed speed*	31 - 1183 in /min	4 in/min		X
Inductance	0 - 100%	1%	X	X
Pulse current**	100 - 650 A	4 A	X	
Pulse time	1.7 - 25.5 ms	0.1 ms	X	
Pulse frequency	16 - 312 Hz	2 Hz	X	
Background current	4 - 300 A	1 A	X	
Slope	1 - 9	1	X	
Ka	0 - 100%	1%	X	
Ki	0 - 100%	1%	X	
Regulator type		1		
Synergy***	OFF or ON	-	-	-
Phase weld time	0 - 2.50 s	0.01 s		X
Gas pre-flow	0.1 - 25 s	0.1 s		X
Creep start	OFF or ON	-		X
“Hot start”	OFF or ON	-		X
“Hot start” time	0 - 10 s	0.1 s		X
“Hot start” wire feed	Complete wire feed range	4 in/min		X
“Hot start” voltage	-14 - +27 V		X	-
“Touch sense”	0 - 20 A			X
Crater filling	OFF or ON	-		X
(pulsed/not pulsed)				
Crater filling time	0 - 10 s	0.1 s		X
Final crater filling wire feed	59 in/min at current wire feed speed	4 in/min		X
Final crater filling voltage	8 - 33.2 V		X	
Final pulse current	100 - max A		X	
Final background current	12 - 50 A		X	
Final frequency	20 - 270 Hz		X	
Cut-off pulse	%			
Burnback time	0 - 1 s	0.01 s		X
Gas post-flow	0.1 - 25 s	0.1 s		X
Setting limits	1 - 50	-	-	-
Measure limits	1 - 50	-	-	-
Spot welding	OFF or ON	-		X
Spot welding time	0 - 25 s	0.1 s		X
“Release pulse”****	OFF or ON			X

*) The setting range is dependent on the wire feed unit used.

**) Minimal background current and pulse current are dependent on which machine type is used.

***) The synergic line on delivery: solid wire (Fe), shielding gas CO₂ with wire 0,045 inch.

****) Adjusted in the configuration menu MIG/MAG basic settings.

4.1.4 MIG/MAG welding with QSet

Main menu → Process → Method

Settings	Setting range	In steps of
QSet	-18 - +18	1
Wire feed speed*	31 - 1183 in /min	4 in/min
Inductance	0 - 100%	1
Control type	1 - 12	1
Gas pre-flow	0.1 - 25 s	0.1 s
Creep start	OFF or ON	-
Pinch off pulse	10 - 120%	1%
Burnback time	0 - 1 s	0.01 s
Gas post-flow	0.1 - 25 s	0.1 s
Setting limits	1 - 50	-
Measure limits	1 - 50	-
Spot welding	OFF or ON	-
Spot welding time	0 - 25 s	0.1 s

*) The setting range is dependent on the wire feed unit used.

4.2 Function explanations for settings

Voltage

Higher voltage increases the arc length and produces a hotter, wider weld pool.

The voltage setting differs between synergy and non synergy modes. In synergy mode, the voltage is set as a positive or negative offset from the synergic line of the voltage. In non synergy mode, the voltage value is set as an absolute value.

The voltage is set in the measure, weld data setting , or fast mode menus. When the remote control unit is used, the setting can be adjusted from here.



Wire feed speed

This sets the required feed speed of the filler wire in inches per minute.

The wire feed speed is set in the measure, weld data setting , or fast mode menus. When the remote control unit is used, the setting can be adjusted from here.



Inductance

Higher inductance results in a wider weld pool and less spatter. Lower inductance produces a harsher sound but a stable, concentrated arc.

Inductance is set in the weld data setting menu.

Only applies to MIG/MAG welding with short-/sprayarc.

Regulator type

Affects the short circuit process and heat in the weld.

The setting should not be altered.

Pulse current

The higher of the two current values in the event of pulsed current.

Pulse current is set in the weld data setting menu with the synergy function switched off.

Only applies to MIG/MAG welding with pulsing.

Pulse time

The time the pulse current is on during a pulse period.

Pulse current is set in the weld data setting menu with the synergy function switched off.

Only applies to MIG/MAG welding with pulsing.

Pulse frequency

Time for background current which, along with the time for pulse current, gives the pulse period.

Pulse frequency is set in the weld data setting menu with the synergy function switched off.

Only applies to MIG/MAG welding with pulsing.

Background current

The lower of the two current values in the event of pulsed current.

Background current is set in the weld data setting menu with the synergy function switched off. Only applies to MIG/MAG welding with pulsing.

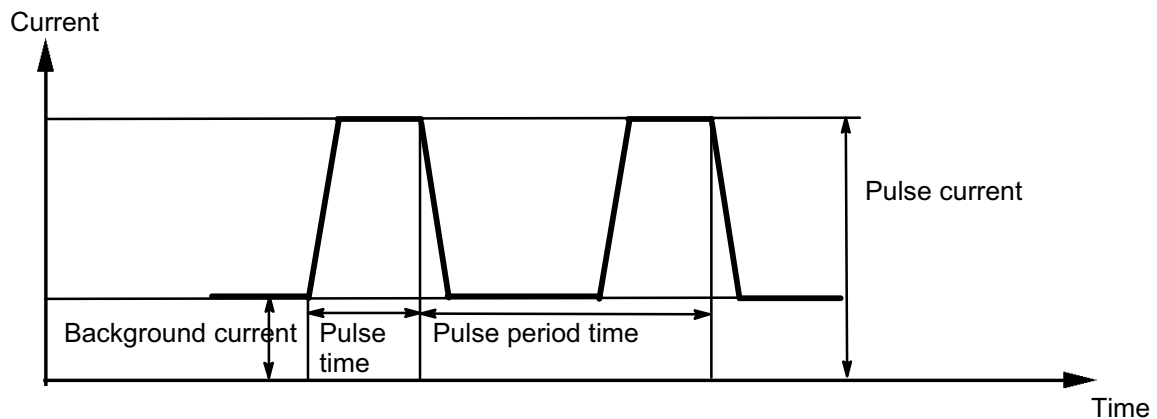

MIG/MAG welding with pulsing.

Slope

“Slope” means that the pulse current slowly increases/decreases to the set value. The “Slope” parameter can be set in nine stages, with each stage corresponding to 100 μ s.

The slope is important as regards the sound. A steep slope produces a louder and sharper sound. Too gentle a slope can, in the worst case scenario, impair the pulse's ability to cut off the droplet.



Slope is set in the weld data setting menu with the synergy function switched off.

Only applies to MIG/MAG welding with pulsing.

Ka

Ka is the proportional element and corresponds to the regulator's amplification. A low value means that the voltage is not maintained at a constant level as precisely.

Ka is set in the weld data setting menu → internal constants with the synergy function switched off.

Only applies to MIG/MAG welding with pulsing.

Ki

Ki is the integrating element that attempts in the longer term to eliminate the fault. Here too, a low value will produce a weaker regulatory effect.

Ki is set in the weld data setting menu → internal constants with the synergy function switched off.

Only applies to MIG/MAG welding with pulsing.

Synergy

Each combination of wire type, wire diameter and gas mixture requires a unique relationship between wire feed speed and voltage (arc length) to obtain a stable, functioning arc. The voltage (arc length) automatically “conforms” to the pre-programmed synergic line you selected, which makes it much easier to find the correct welding parameters quickly. The link between wire feed speed and other parameters is known as the synergic line.

For wire and gas combinations, see the tables on page [83](#).

It is possible to order different packages of synergic lines, although these must be installed by an authorised ESAB service engineer.

For the creation of own synergic lines, see chapter [10.8](#)

Activation of the synergy takes place in the weld data setting menu.

Phase

In this function, the choice is made between primary and secondary.

High data is set in primary and low data is set in secondary.

The settings are used to determine whether primary or secondary data should be available for editing. It also determines which data are affected in measuring and remote modes. The wire feed speed shown in the measure screen shows the speed in the selected phase. However, the voltage, current and weld output are based on the measurement under both phases.

You can choose different synergy in the primary and secondary phases.

Primary or secondary phase is set in MIG/MAG SET when Superpulse is selected and synergy is switched off.



Gas pre-flow

This controls the time during which shielding gas flows before the arc is struck.

Gas pre-flow is set in the weld data setting menu → start data.



Slow run in

Slow run in starting feeds out the wire at 50% of the set speed until it makes electrical contact with the workpiece.

With hot start it is 50% of the hot start time.

Creep start is set in the weld data setting menu → start data.

“Hot start”

“Hot start” increases the wire feed speed and the voltage for an adjustable time at the start of the welding process. The main purpose of this is to provide more energy when starting welding, which reduces the risk of poor fusion at the beginning of the joint.

Hot start – wire feed

It is possible to increase the wire feed speed during a specific period compared to the present wire feed speed to provide more energy during the weld start and ensure penetration. The speed is set relative to the ordinary wire feed speed. The time starts when the arc is ignited and the length is the set hot start time. Synergy gives an increase in the wire speed of 2 m/min.

Hot start – voltage

The voltage increases by 2 volts in addition to the contribution from the synergic line slope and the extra 2 m/min in wire feed speed. In non synergy mode, the voltage in question will be the one set and it is not synergy dependent.

Note! It is possible to set negative values for the hot start wire feed and hot start voltage. This can be used with high weld data to give a smooth weld start by initially “stepping up” the weld data.

Hot start is activated in the measure screen or in the weld data setting menu → start data.

Touch sense

The system detects when the wire comes into contact with the workpiece.

Touch sense is set in the weld data setting menu → start data.

Only applies to robot welding.

Crater filling

Crater filling makes a controlled reduction in the heat and size of the weld pool possible when completing the weld. This makes it easier to avoid pores, thermal cracking and crater formation in the weld joint.

In pulse welding mode, it is possible to choose between pulsed and non pulsed crater filling. Non pulsed crater filling is the faster process. Pulsed crater filling takes a little longer, yet gives spatter free crater filling when appropriate values are used.

Synergy – crater filling

In synergy mode, the crater filling time and the final wire feed speed are set in both pulsed and non pulsed crater filling. The voltage and the pulse parameters drop to the final values with the help of synergy.

Non synergy – crater filling

In non synergy mode, the settings can be changed to give another arc length at the end of crater filling.

The final voltage can be set for non pulsed crater filling. The final voltage, final pulse current, final background current and the final frequency can be set for pulsed crater filling.

The final parameter values must always be equal to or lower than the set values for continuous welding. If the settings for continuous welding are lowered below the set final values, they will also lower the final values. The final parameter values will not increase again if the setting for continuous welding is increased.

Example:

You have 4 m/min as the final wire feed speed and lower the wire feed speed to 3.5 m/min. The final wire feed speed will also be lowered to 3.5 m/min. The final wire speed remains at 3.5 m/min even when the wire feed speed is increased again.

Crater filling is activated in the measure screen or in the weld data setting menu → stop data.

Pinch-off pulse

Pinch-off pulse is a pulse that is applied to ensure that a ball is not formed on the wire when welding stops.

Only applies to MIG/MAG welding with short-/sprayarc. When pulsing, completion is synchronised with a pulse, finishing pulse.

Pinch-off pulse is set in the weld data setting menu → stop data.



Burnback time

Burnback time is a delay between the time when the wire starts to brake until the time when the power source switches off the welding voltage. Too short burnback time results in a long wire stickout after completion of welding, with a risk of the wire being caught in the solidifying weld pool. Too long a burnback time results in a shorter stickout, with increased risk of the arc striking back to the contact tip.

Burnback time is set in the weld data setting menu → stop data.

Release pulse

If the wire becomes trapped in the workpiece, the system detects this. A current pulse is sent out that releases the wire from the surface.

This applies in particular to mechanised and robotised welding, although it can also be used during manual welding. Occurs after completed burnback time.

The setting is adjusted in the Configuration menu → MIG/MAG defaults.



Gas post-flow

This controls the time during which shielding gas flows after the arc is extinguished.

Gas post-flow is set in the weld data setting menu → stop data.

Setting limits and measure limits

In limits, a limit number is selected. For settings, see the chapter [10.4](#) “Edit setting limits” and the chapter [10.5](#) “Edit measure limits”.

Limits are activated in the weld data setting menu.

Spot welding

Spot welding is used when you want to spot weld thin plates together.

NOTE! It is *not* possible to shorten the welding time by releasing the trigger switch.

Spot welding is activated and spot welding time is set in the weld data setting menu.

QSet

QSet is a function used to facilitate the setting of welding parameters. See more in chapter [4.4](#).

The QSet value is set in the weld data setting menu for process MIG/MAG and method QSET.

4.3 SuperPulse

Main menu → Process → Method

The SuperPulse method is used for improved control of the weld pool and the solidification process. The weld pool has time to solidify partially between each pulse.

Benefits of using SuperPulse:

- Less sensitivity to root gap variations
- Better control of the weld pool during position welding
- Better control of penetration and penetration profile
- Reduced sensitivity to uneven heat conduction

SuperPulse can be seen as a programmed changeover between two MIG/MAG settings. The time intervals are determined by the primary and secondary phase time settings.

Welding always starts in the primary phase. When hot start is selected, primary data will be used during the hot start time in addition to the phase time for the primary data. Crater filling is always based on secondary data. When a stop command has been activated during the primary phase time, the process immediately switches to secondary data. The weld completion is based on secondary data.

4.3.1 Wire and gas combinations

For wire and gas combinations, see the tables on page [83](#).

4.3.2 Different pulsing methods

Below you can see which pulsing method can be used, depending on the plate thickness that is to be welded.

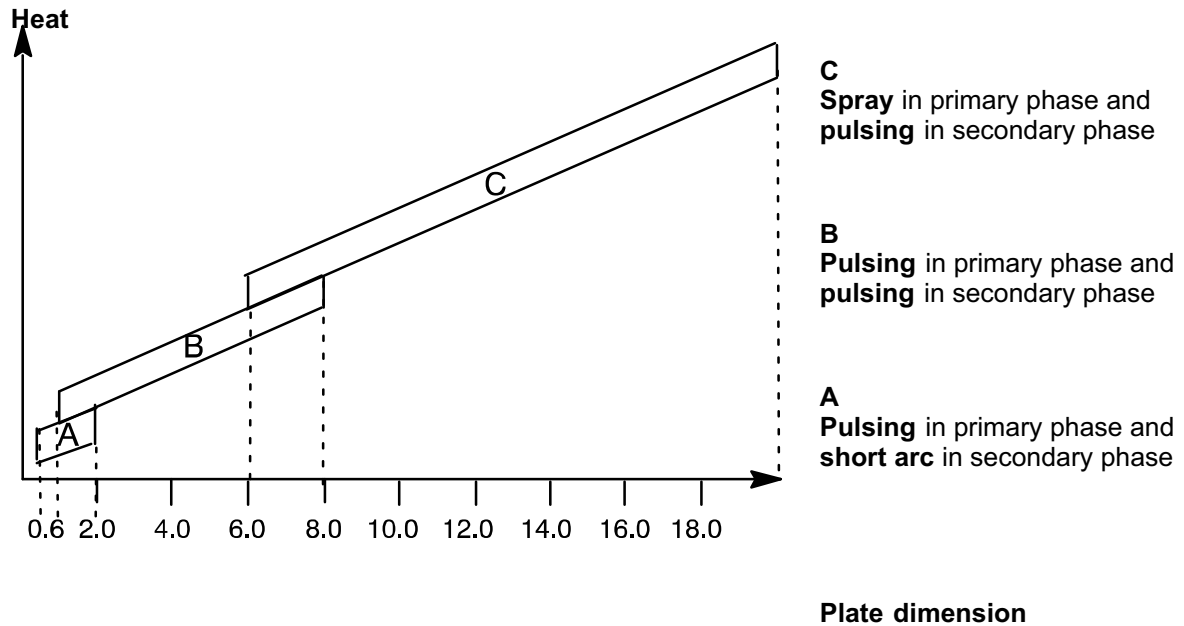

4.3.3 Wire feed unit

Only use wire feed unit Feed 3004 during SuperPulse welding.

Precautionary measures!

When using SuperPulse, there is a considerable load on the wire feed unit. In order of the functional safety of the wire feed unit not to be endangered, follow the limit values in the following diagram.

Difference in the wire feed speed

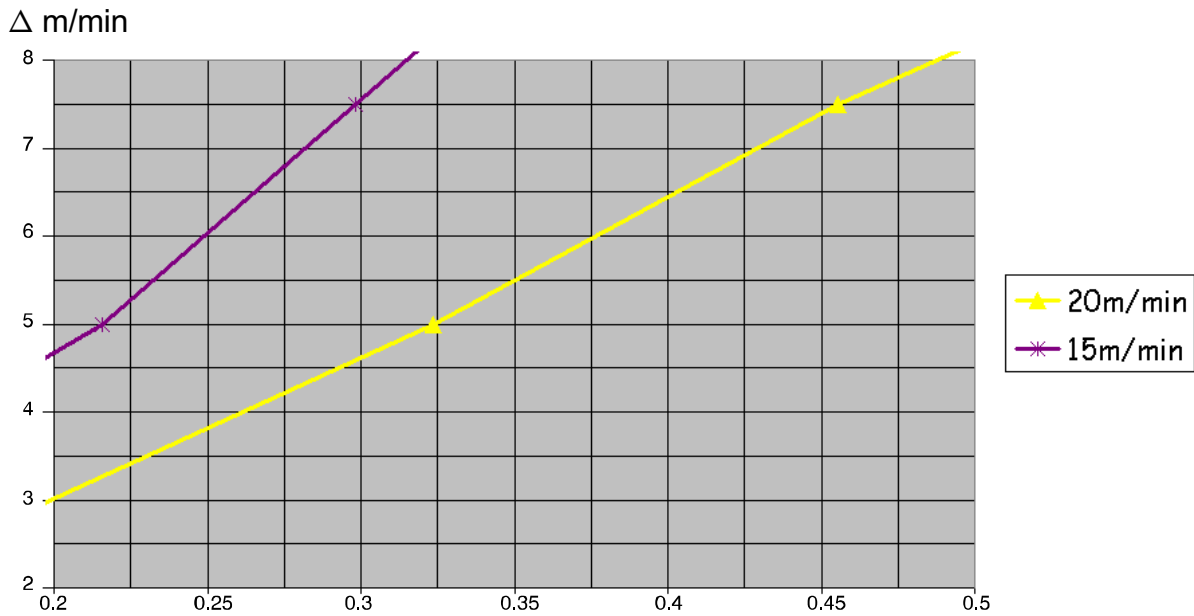

The graphs for 15 m/min (592 in/min) and 20 m/min (789 in/min) relate to primary wire feed speed. The cycle time is the sum of primary and secondary phase time.

The difference between primary and secondary wire feed speed may not exceed the speed that is specified by the graphs for primary wire speed.

Example: If the cycle time is 0.25 s and the primary wire feed speed is 15 m/min, the difference between primary and secondary wire feed speed may not exceed 6 m/min.

Weld example A

In this example we will weld a **0.394 inch plate** with **0.045 inch aluminium wire** and **argon shielding gas**

Make the following settings with the control panel:

Process	Superpulse	Superpulse
Phase	Primary	Secondary
Method	Short-/Sprayarc	Pulsing
Wire type	AlMg	AlMg
Shielding gas	Ar	Ar
Wire diameter	0.045 inch	0.045 inch
Voltage	(+ 1.0V)	(+ 3.0V)
Wire feed speed	592 in/min	434 in/min
Phase time	0.1 s	0.1 s

Primary and secondary phase time are 0.1 s + 0.1 s = **0.2 s**.

The difference in wire feed speed is 592 in/min - 434 in/min = **158 in/min**.

Weld example B

In this example we will weld a **0.236 inch plate** with **0.045 inch aluminium wire** and **argon shielding gas**.



Make the following settings with the control panel:

Process	Superpulse	Superpulse
Phase	Primary	Secondary
Method	Pulsing	Pulsing
Wire type	AlMg	AlMg
Shielding gas	Ar	Ar
Wire diameter	0.045 inch	0.045 inch
Voltage	(+ 1.0V)	(+ 2.0V)
Wire feed speed	493 in/min	355 in/min
Phase time	0.15 s	0.15 s

Primary and secondary phase time are $0.15\text{ s} + 0.15\text{ s} = \mathbf{0.3\text{ s}}$.

The difference in wire feed speed is $493\text{ in/min} - 355\text{ in/min} = \mathbf{138\text{ in/min}}$.

4.4 QSet

Main menu → Process → Method

QSet is used to facilitate setting welding parameters. Using the plus/minus knobs, the arc length is increased or decreased from -18 to + 18 steps.

SHORT ARC

When first starting welding with a new wire type/gas type, QSet automatically sets all the necessary welding parameters. After that QSet stores all the data to produce a good weld. The voltage then automatically conforms to changes in the wire feed speed.

SPRAY

When approaching the spray arc area, the value for QSet must be increased. Disengage the QSet function when welding with pure spray arc. All settings are inherited from QSet, with the exception of the voltage which must be set.

Recommendation: Make the first weld (6 seconds) with QSet on a test piece to obtain all the correct data.

5 MMA WELDING

Main menu → Process

MMA welding may also be referred to as welding with coated electrodes. Striking the arc melts the electrode, and its coating forms protective slag.

The table on page 85 shows the electrode diameters that can be selected for MMA welding.

5.1 MMA welding DC

Settings	Setting range	In steps of	Synergy dependent	Ad-justable in synergy
Current*	16 - 650 A	1 A		x
Arc force	0 - 100%	1%	x	
Min. current factor	0 - 100%	1%	x	
Regulator type	0 - 1		x	
Synergy	OFF or ON	-	-	-
Hot start	OFF or ON	-	x	
Hot start duration	1 - 30	1	x	
Hot start amplitude	%	-	x	
Setting limits	0 - 50	1	-	-
Measure limits	0 - 50	1	-	-

*) Maximum current depending on which machine type is being used.

5.2 MMA welding AC

Settings	Setting range	In steps of	Synergy dependent	Ad-justable in synergy
Current*	16 - 650 A	1 A		x
Arc force	0 - 100%	1%	x	
Min. current factor	0 - 100%	1%	x	
Regulator type	0 - 1		x	
Synergy	OFF or ON	-	-	-
Hot start	OFF or ON	-	x	
Hot start duration	1 - 30		x	
Hot start amplitude	%	-	x	
Setting limits	0 - 50	1	-	-
Measure limits	0 - 50	1	-	-

*) Maximum current depending on which machine type is being used.

5.3 Function explanations for settings



DC, Direct current

A higher current produces a wider weld pool, with better penetration into the work-piece.

The current is set in the measure screen, weld data setting , or fast mode menus.



Arc force

The arc force is important in determining how the current changes in response to a change in the arc length. A lower value gives a calmer arc with less spatter.

The arc force is set in the weld data setting menu when the synergy function is deactivated.

Min. current factor

The setting of min. current factor is employed when using certain specific electrodes.

The setting should not be altered.

Regulator type

Affects the short circuit process and heat in the weld.

The setting should not be altered.

Synergy

Synergy for MMA welding means that the power source automatically optimises the properties for the electrode type and dimension that have been selected.

Synergy for MMA welding is activated in the weld data setting menu.



Hot start

Hot start increases the weld current for an adjustable time at the start of welding, thus reducing the risk of poor fusion at the beginning of the joint.

Hot start for MMA is activated in the weld data setting menu.

Setting limits and measure limits

In limits, a limit number is selected. For settings, see the chapter [10.4](#) “Edit setting limits” and the chapter [10.5](#) “Edit measure limits”.

Limits are activated in the weld data setting menu.

6 GTAW WELDING

Main menu → Process



GTAW welding

GTAW welding melts the metal of the workpiece, using an arc struck from a tungsten electrode, which does not melt itself. The weld pool and the electrode are protected by shielding gas.



Pulsed current

Pulsing is used for improved control of the weld pool and the solidification process. The pulse frequency is set so slow that the weld pool has time to solidify at least partially between each pulse. In order to set pulsing, four parameters are required: pulse current, pulse time, background current and background time.

6.1 Settings in the weld data setting menu

6.1.1 GTAW welding without pulsing DC

Settings	Setting range	In steps of
HF/LiftArc™	HF or LiftArc	-
2/4 stroke	2 stroke or 4 stroke	-
Current*	4 - 500 A	1 A
Slope up time	0 - 25 s	0.1 s
Slope down time	0 - 25 s	0.1 s
Gas pre-flow	0 - 25 s	0.1 s
Gas post-flow	0 - 25 s	0.1 s
Setting limits	0 - 50	1
Measure limits	0 - 50	1

*) Maximum current depending on which machine type is being used.

6.1.2 GTAW welding with pulsing DC

Settings	Setting range	In steps of
HF/LiftArc™	HF or LiftArc	-
2/4 stroke	2 stroke or 4 stroke	-
Pulse current*	4 - 500 A	1 A
Background current	4 - 500 A	1 A
Pulse time	0.001 - 5 s	0.001 s
Background time	0.001 - 5 s	0.001 s
Slope up time	0 - 25 s	0.1 s
Slope down time	0 - 25 s	0.1 s
Gas pre-flow	0 - 25 s	0.1 s
Gas post-flow	0 - 25 s	0.1 s
Setting limits	0 - 50	1
Measure limits	0 - 50	1

*) Maximum current depending on which machine type is being used.

6.1.3 GTAW welding without pulsing AC

Settings	Setting range	In steps of
HF/LiftArc™	HF or LiftArc	-
2/4 stroke	2 stroke or 4 stroke	-
Current*	4 - 500 A	1 A
Slope up time	0 - 25 s	0.1 s
Slope down time	0 - 25 s	0.1 s
Gas pre-flow	0 - 25 s	0.1 s
Gas post-flow	0 - 25 s	0.1 s
Preheating	0 - 100	1
Frequency	Hz	?
Balance	%	1%
Offset	A	
Setting limits	0 - 50	1
Measure limits	0 - 50	1

*) Maximum current depending on which machine type is being used.

6.2 Function explanations for settings



The HF function strikes the arc by means of a spark from the electrode to the workpiece as the electrode is brought closer to the workpiece.

HF is activated in the main menu → start method.



The LiftArc™ function strikes the arc when the electrode is brought into contact with the workpiece and then lifted away from it.

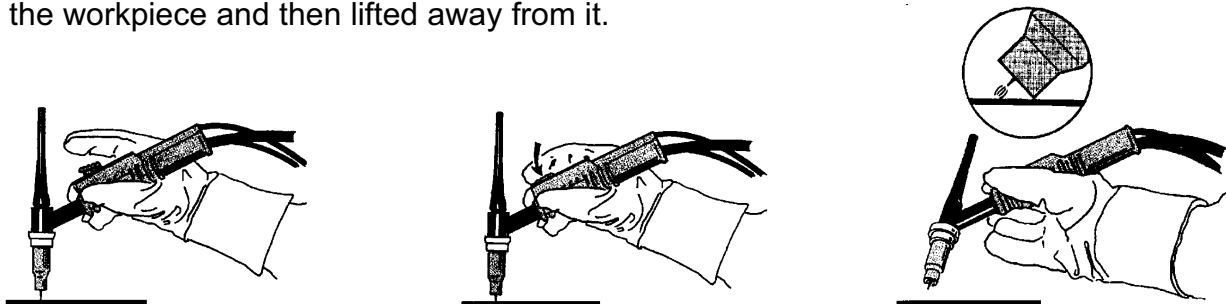

Striking the arc with the LiftArc function™. Step 1: the electrode is touched on to the workpiece. Step 2: the trigger switch is pressed, and a low current starts to flow. Step 3: the welder lifts the electrode from the workpiece: the arc strikes, and the current rises automatically to the set value.

LiftArc™ is activated in the main menu → start method.

2-stroke

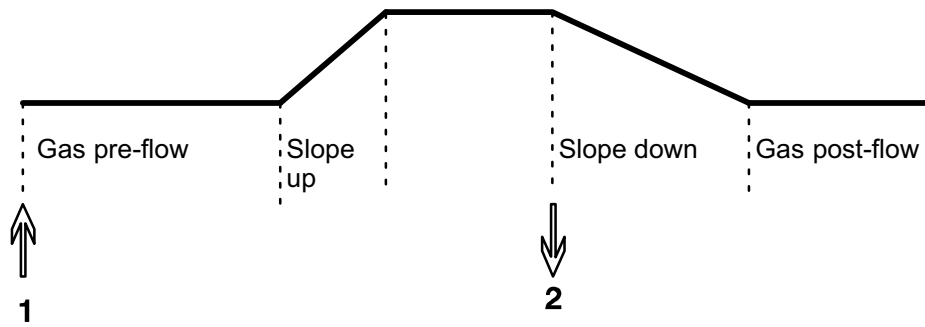

Functions when using 2 stroke control of the welding torch.

In the 2 stroke control mode, pressing the TIG torch trigger switch (1) starts gas pre-flow (if used) and strikes the arc. The current rises to the set value (as controlled by the slope up function, if in operation). Releasing the trigger switch (2) reduces the current (or starts slope down if in operation) and extinguishes the arc. Gas post-flow follows if it is in operation.

2-stroke is activated in the main menu → trigger mode or in the measure screen.

4-stroke

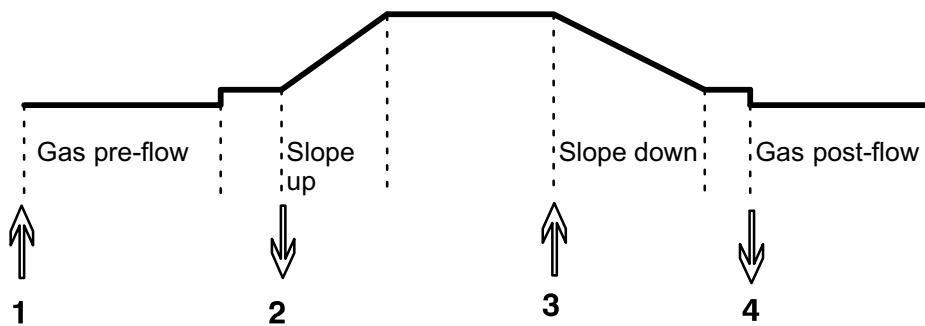

Functions when using 4 stroke control of the welding torch.

In the 4 stroke control mode, pressing the trigger switch (1) starts gas pre-flow (if used). At the end of the gas pre-flow time, the current rises to the pilot level (a few ampere), and the arc is struck. Releasing the trigger switch (2) increases the current to the set value (with slope up, if in use). At the end of welding, the welder presses the trigger switch again (3), which reduces the current to pilot level again (with slope down, if in use). Releasing the switch again (4) extinguishes the arc and starts gas post-flow.

4-stroke is activated in the main menu → trigger mode or in the measure screen.

Current

A higher current produces a wider weld pool, with better penetration into the workpiece.

The current is set in the measure screen, weld data setting , or fast mode menus.

Only applies to TIG welding with constant current.

Pulse current

The higher of the two current values in the event of pulsed current. When pulsing, slope up and slope down are also pulsed.

Pulse current is set in the weld data setting menu.

Only applies to TIG welding with pulsing.

Background current

The lower of the two current values in the event of pulsed current.

Background current is set in the weld data setting menu.

Only applies to TIG welding with pulsing.

Pulse time

The time the pulse current is on during a pulse period.

Pulse time is set in the weld data setting menu.

Only applies to TIG welding with pulsing.

Background time

Time for background current which, along with the time for pulse current, gives the pulse period.

Background time is set in the weld data setting menu.

Only applies to TIG welding with pulsing.

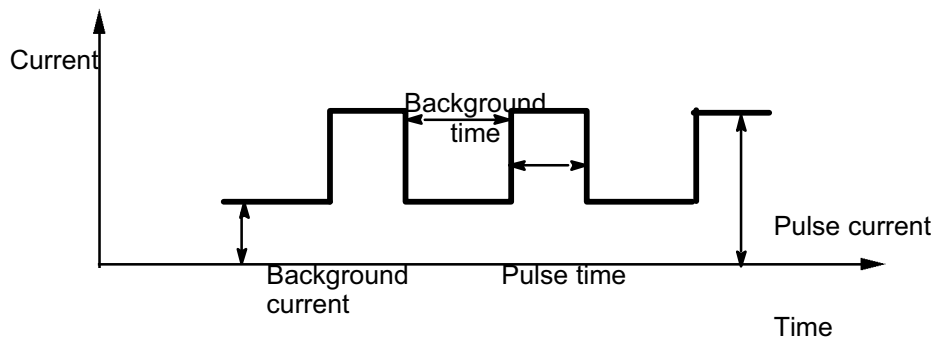

TIG welding with pulsing.

 **Slope up**

The slope up function means that, when the TIG arc strikes, the current rises slowly to the set value. This provides 'gentler' heating of the electrode, and gives the welder a chance to position the electrode properly before the set welding current is reached.

Slope up is set in the weld data setting menu.

 **Slope down**

TIG welding uses "slope down", by which the current falls 'slowly' over a controlled time, to avoid craters and/or cracks. when a weld is finished.

Slope down is set in the weld data setting menu.



Gas pre-flow

This controls the time during which shielding gas flows before the arc is struck.

Gas pre-flow is set in the weld data setting menu.



Gas post-flow

This controls the time during which shielding gas flows after the arc is extinguished.

Gas post-flow is set in the weld data setting menu.

Preheating

Tungsten electrode				Setting value	
				Shielding gas	
Ø	Colour	Type		Ar	Ar + 30%He
1/16"	Green	WP		-	-
1/16"	Green	WP		30	35
1/16"	Golden	WL15		20	20
1/16"	Golden	WL15		30	35
3/32"	Green	WP		45	-
3/32"	Green	WP		55	60
3/32"	Golden	WL15		40	40
3/32"	Golden	WL15		45	50
1/8"	Green	WP		55	-
1/8"	Green	WP		65	65
1/8"	Golden	WL15		60	60
1/8"	Golden	WL15		70	70
5/32"	Green	WP		70	75
5/32"	Green	WP		80	85
5/32"	Golden	WL15		65	65
5/32"	Golden	WL15		70	75

WP = Pure tungsten electrode WL15 = Lantha alloyed tungsten electrode

Electrode preheating is set in the weld data setting menu.

Only applies to TIG welding with AC.



Frequency

Lower frequency (alternating current) transfers more heat to the workpiece and produces a wider weld pool.

Higher frequency produces a narrower arc with higher arc force (narrower weld pool).

Gas post-flow is set in the weld data setting menu.

Only applies to TIG welding with AC.

Balance

Setting the balance between the positive (+) electrode and negative (-) electrode half period during alternating current welding (AC).

Lower balance value produces more heat on the electrode and better oxide break-up on the workpiece.

Higher balance value produces more heat to the workpiece and better penetration.

Balance is set in the weld data setting menu.

Only applies to TIG welding with AC.

Offset

Using this function, the zero level is raised or lowered.

With a raised zero level, the workpiece becomes hotter and achieves better penetration.

With a lowered zero level, the electrode becomes hotter and the workpiece achieves poorer penetration.

Offset is set in the weld data setting menu.

Only applies to TIG welding with AC.

6.3 Other function explanations



Gas purging

Gas purging is used when measuring the gas flow or to flush any air or moisture from the gas hoses before welding starts. Gas purging occurs for as long as the button is held depressed and occurs without voltage or wire feed starting.

Gas purging is activated in the measure screen.

7 ARC AIR GOUGING

Main menu → Process

With arc air gouging, a special electrode comprising a carbon rod with a copper casing is used.

An arc is formed between the carbon rod and the workpiece, which melts the material. Air is supplied so that the melted material is blown away.

Arc air gouging is not recommended for power sources below 400 A.

7.1 Settings in the weld data setting menu

Settings	Setting range	In steps of	Synergy dependent	Adjustable in synergy
Voltage	8 - 60 V	1 V	x	x
Synergy*	OFF or ON	-	-	-
Inductance	0 - 100%		x	
Regulator type	1 - 12	1	x	

*) The synergic line on delivery: 3/16" electrode (carbon rod).

7.2 Function explanations

Voltage

A higher voltage produces a wider weld pool, with better penetration into the workpiece.

The voltage is set in the measure screen, weld data setting or fast mode menus.

Inductance

NOTE! The setting should not be altered.

Regulator type

Affects the short circuit process and heat in the weld.

The setting should not be altered.

8 MEMORY MANAGEMENT

8.1 Control panel working method

The control panel can be said to comprise two units: working memory and weld data memory.

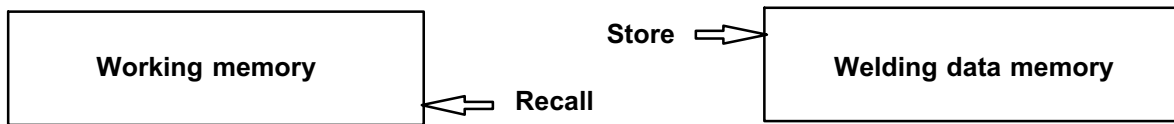

In the working memory, a complete set of weld data settings is created that can be stored in the weld data memory.

During welding, it is always the content of the working memory that controls the process. It is therefore also possible to recall a weld data set from the weld data memory to the working memory.

Note that the working memory always contains the most recently set weld data settings. They can be recalled from the weld data memory or individually altered settings. In other words, the working memory is never empty or “zeroed”.

Main menu → Memory → Weld data memory

MIG/MAG	
PROCESS	MIG/MAG
METHOD	SHORT/SPRAY
WIRE TYPE	Fe
SHIELDING GAS	Ar+8%CO2
WIRE DIAMETER	0.045"
CONFIGURATION ▶	
TOOLS ▶	

SET	MEASURE	MEMORY	FAST MODE
-----	---------	--------	-----------

It is possible to **store up to 255 sets of** weld data in the control panel. Each set is given a number from 1 to 255.

You can also **delete** and **copy** data sets and **recall** a set of weld data to the working memory.

Below are examples showing how to store, recall, copy and delete.

8.2 Store

If the weld data memory is empty, the following screen appears in the display.

We are now going to store a set of weld data. It will be given memory position 5. Press STORE.

WELD DATA MEMORY				
STORE				QUIT

Select row five using one of the knobs. Press STORE.

WELD DATA MEMORY				
5 -				
STORE				QUIT

The following screen appears in the display.

The weld data set you entered is now stored in row 5.

WELD DATA MEMORY				
5 - (TIG)				
TIG HF-START 100 AMP				
STORE	RECALL	DELETE	2ND FUNCT	QUIT

The data set is now stored as number 5. Parts of the content of data set number 5 are presented at the bottom of the display.

8.3 Recall

We are going to recall a stored data set:

Select the row using one of the knobs. Press RECALL.

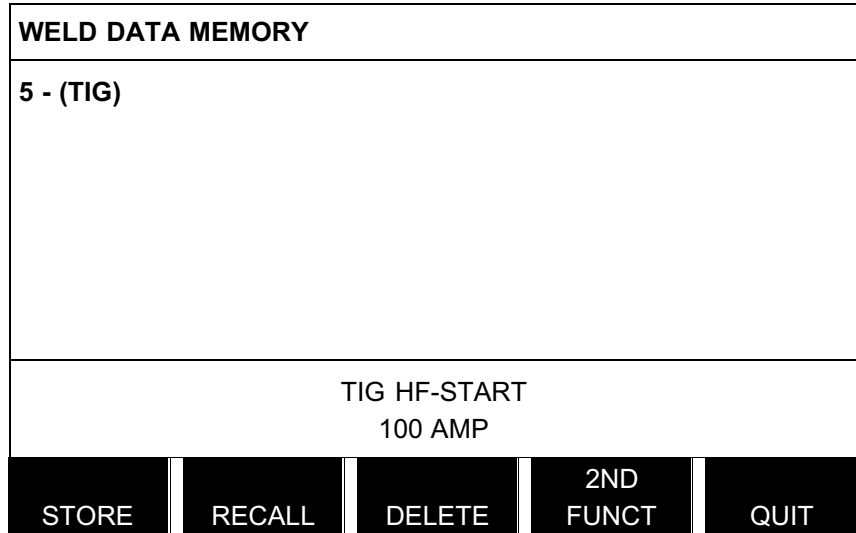

Press YES to confirm that you want to recall data set number 5.

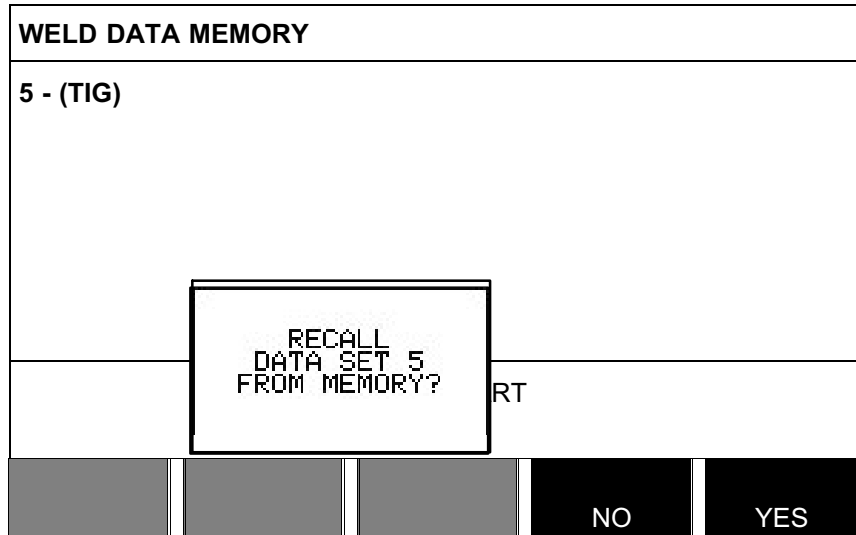

This icon in the measure screen shows which memory position number has been recalled.

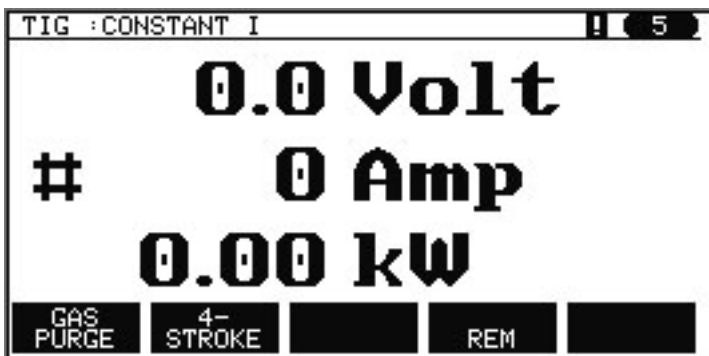

8.4 Delete

It is possible to delete one or more data sets in the memory menu.

We are going to delete the data set we stored in an earlier example.

Select the data set.
Press DELETE.

WELD DATA MEMORY				
5 - (TIG)				
TIG HF-START 100 AMP				
STORE	RECALL	DELETE	2ND FUNCT	QUIT

Press YES to confirm
that you want to delete.

WELD DATA MEMORY				
5 - (TIG)				
DELETE WELD DATA NR. 5? RT				
			NO	YES

Return to the memory menu with the NO key.

8.5 Copy

To copy the content of a weld data set to a new memory position, proceed as follows:

Select the memory position you want to copy and press 2ND FUNCT.

WELD DATA MEMORY				
5 - (TIG)				
TIG HF-START 100 AMP				
STORE	RECALL	DELETE	2ND FUNCT	QUIT

Press COPY.

WELD DATA MEMORY				
5 - (TIG)				
TIG HF-START 100 AMP				
COPY		EDIT	2ND FUNCT	QUIT

We are now going to copy the content of memory position 5 to position 50.

Use one of the knobs to step to the selected memory position, in this case position 50.

Press YES.

WELD DATA MEMORY				
50 -				
COPY DATA SET 5 TO POSITION: 50				
			NO	YES

Weld data number 5 has now been copied to memory position 50.

Return to the memory menu with QUIT.

8.6 Edit

To edit the content of a weld data set, proceed as follows:

Select the memory position you want to edit and press 2ND FUNCTION. Then press EDIT.

WELD DATA MEMORY				
5 - (TIG)				
TIG HF-START 100 AMP				
COPY		EDIT	2ND FUNCT	QUIT

Part of the main menu is displayed and the menu shows the symbol  which means that you are in an editing mode.

Select the setting you want to edit and press ENTER. Select from the list and press ENTER again.

TIG 	
START METHOD GUN TRIGGER MODE	HF-START 4-STROKE
TIG HF-START 100 AMP	
SET	QUIT

Press SET to move to WELD DATA SETTING. Select the values you want to edit and adjust with the plus/minus knobs. End with QUIT.

WELD DATA SETTING 	
CURRENT	100 A
SLOPE UP TIME	0.0 S
SLOPE DOWN TIME	2.0 S
GAS PREFLOW	0.5 S
GAS POSTFLOW	5.0 S
SETTING LIMITS	-
MEASURE LIMITS	-
EDIT DESCRIPTION
GAS PURGE	4-STROKE
REM	QUIT

The setting for weld data number 5 has now been edited and stored.

8.7 Name

To give a stored weld data set its own name, proceed as follows:

Select the memory position you want to name and press 2ND FUNCTION. Then press EDIT.

WELD DATA MEMORY				
5 - (TIG)				
TIG HF-START 100 AMP				
COPY		EDIT	2ND FUNCT	QUIT

Press SET to move to WELD DATA SETTING. Select EDIT DESCRIPTION. Press ENTER.

WELD DATA SETTING 	
CURRENT	100 A
SLOPE UP TIME	0.0 S
SLOPE DOWN TIME	2.0 S
GAS PREFLOW	0.5 S
GAS POSTFLOW	5.0 S
SETTING LIMITS	-
MEASURE LIMITS	-
EDIT DESCRIPTION
GAS PURGE	4- STROKE
REM	QUIT

Here you have access to a keyboard that is used as follows:

- Position the cursor on the desired keyboard character using the left-hand knob and the arrow keys. Press ENTER. Enter a complete character string with a maximum of 40 characters in this way.
- Press DONE to store. The alternative you have named can now be seen in the list.

KEYBOARD 																																											
<table border="0"> <tr> <td><input checked="" type="checkbox"/></td><td>B</td><td>C</td><td>D</td><td>E</td><td>F</td><td>G</td><td>H</td> </tr> <tr> <td>I</td><td>J</td><td>K</td><td>L</td><td>M</td><td>N</td><td>O</td><td>P</td> </tr> <tr> <td>Q</td><td>R</td><td>S</td><td>T</td><td>U</td><td>V</td><td>W</td><td>X</td> </tr> <tr> <td>0</td><td>1</td><td>2</td><td>3</td><td>4</td><td>5</td><td>6</td><td>7</td> </tr> <tr> <td>8</td><td>9</td><td>SPACE</td><td>CAPS</td><td></td><td></td><td></td><td></td> </tr> </table>	<input checked="" type="checkbox"/>	B	C	D	E	F	G	H	I	J	K	L	M	N	O	P	Q	R	S	T	U	V	W	X	0	1	2	3	4	5	6	7	8	9	SPACE	CAPS					<table border="0"> <tr> <td>Y</td><td>Z</td> </tr> </table>	Y	Z
<input checked="" type="checkbox"/>	B	C	D	E	F	G	H																																				
I	J	K	L	M	N	O	P																																				
Q	R	S	T	U	V	W	X																																				
0	1	2	3	4	5	6	7																																				
8	9	SPACE	CAPS																																								
Y	Z																																										
0(MAX 40)																																											
←	→																																										
DELETE	SYMBOL																																										
DONE																																											

9 CONFIGURATION MENU

Main menu → Configuration menu

This menu contains the following sub-menus:

- Language, see chapter “First step – choice of language” 2.4.
- Code lock, see chapter 9.1
- Remote control, see chapter 9.2
- MIG/MAG basic defaults, see chapter 9.3
- MMA basic defaults, see chapter 9.4
- Fast mode soft buttons, see chapter 9.5
- Double start sources, see chapter 9.6
- Panel remote enable, see chapter 9.7
- Auto save mode, see chapter 9.8
- Trigger weld data switch, see chapter 9.2.
- Multiple wire feeders, see chapter 9.10.
- Quality functions, see chapter 9.2
- Maintenance, see chapter 9.12
- Unit of length, see chapter 2.5
- Measure value frequency, see chapter 9.13

9.1 Code lock

Main menu → Configuration menu → Code lock

When the lock function is activated and you are in the measure screen, remote mode or fast mode menu, a password (lock code) is required to exit from these menus.

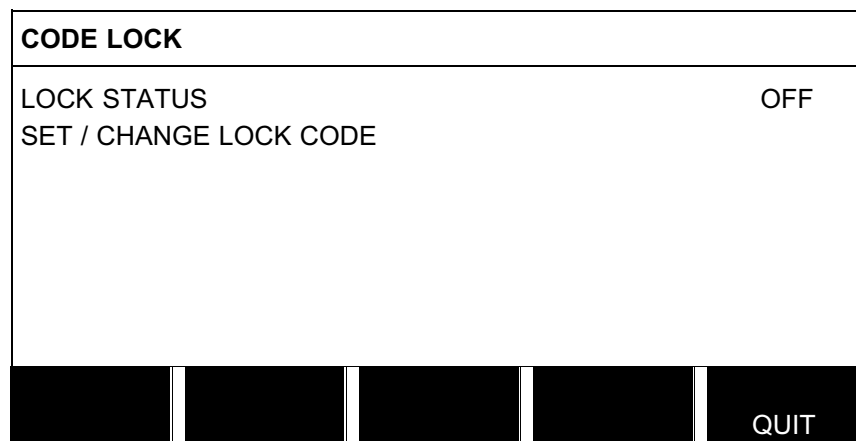

Code lock is activated in the configuration menu.

9.1.1 Lock code status

In lock code status, you can activate/deactivate the lock function without deleting the existing lock code in the event you deactivate the function. If no lock code is stored and you try to activate the code lock, the keyboard is displayed for entering a new lock code.



To exit lock status.

When you are in the measure screen or the fast mode menu and the code lock is **deactivated**, you can exit these menus without restrictions by press QUIT or MENU in order to go to the menu menu.

If it is **activated** and you try to exit, the following screen appears in order to warn the user about the lock protection.

PRESS ENTER FOR LOCK CODE...

PRESS ENTER FOR
LOCK CODE...

Here you can select QUIT to undo and return to the previous menu, or proceed by pressing ENTER to enter the lock code.

You will then move to the menu with the keyboard, where you can enter the code. Press ENTER after each character, and confirm the code by pressing DONE.

The following text box appears:

UNIT UNLOCKED!

UNIT UNLOCKED!

If the code is not correct, an error message is displayed that offers the option of trying again or returning to the original menu, i.e. the measure screen or the fast mode menu.

If the code is correct, all blocks to other menus will be removed, although the code lock remains activated. This means that you can leave the measure screen and the fast mode menu temporarily, yet still retain the lock status when you return to these menus.

9.1.2 Specify/edit lock code

In specify/edit lock code, you can edit an existing lock code or enter a new one. A lock code can comprise a maximum of 16 optional letters or figures.

9.2 Remote controls

Main menu → Configuration menu → Remote controls

Non CAN-bus connected remote control units must be connected via a remote control adapter. The SuperPulse method is not supported by this function.

After connection, activate the remote control unit in the measure screen with the soft key REMOTE.

9.2.1 Forget override

Place the cursor on the REMOTE CONTROLS row. Press ENTER to bring up a list of alternatives.

MIG/MAG REMOTE CONTROLS	
FORGET OVERRIDE	ON
DIGITAL OP	5-PROG
ANALOG 1	WIRE SPEED
-MIN	.030
-MAX	986
ANALOG 2	VOLTAGE
-MIN	-10
-MAX	+10
QUIT	

With FORGET OVERRIDE in the “ON” position, the most recently recalled memory is automatically recalled before each new welding start. This is to eliminate the results of all weld data settings produced during the most recent welding procedure.

9.2.2 Configuration for digital remote control unit

Without remote control adapter

When connecting a CAN-based remote control unit, configuration takes place automatically, DIGITAL OP.

With remote control adapter

When using a digital remote control unit, specify which type of remote control unit is being used.

Position the cursor on the DIGITAL OP row and press ENTER to bring up of list, from which you can select an alternative.

BINARY CODED
10-PROGR

- 32-program unit BINARY CODED
- 10-program unit * 10-PROGR

* or Welding gun with RS3 program selection

9.2.3 Configuration for analogue remote control unit

Without remote control adapter

When connecting a CAN-based remote control unit, configuration of ANALOG 1 and ANALOG 2 takes place automatically. The configuration cannot be altered.

With remote control adapter

When you use an analogue remote control unit, you can specify on the control panel which (maximum 2) potentiometer(s) you want to use.

The potentiometers are called ANALOG 1 and ANALOG 2 in the control panel and refer to their own set parameters for the welding process, e.g. wire feed parameter (ANALOG 1) and voltage parameter (ANALOG 2) with MIG/MAG.

If you position the cursor on the ANALOG 1 row and press ENTER, this brings up a list.



You can now select whether the potentiometer ANALOG 1 is to be used for WIRE SPEED or if it is not to be used, NONE.

Select the WIRE SPEED row and press ENTER.

If you position the cursor on the ANALOG 2 row and press ENTER, this brings up a list.



You can now select whether the potentiometer ANALOG 2 is to be used for VOLTAGE or if it is not to be used, NONE.

Select the VOLTAGE row and press ENTER.

All configuration for the remote control unit applies to any connected wire feed units. If you remove ANALOG 1 in the configuration, this applies to both wire feed units when you are using twin units.

9.2.4 Scale on inputs

You can set the control range for the potentiometer(s) that is to be used. This is done by specifying a minimum value and a maximum value in the control panel with the plus/minus knobs.

Note that you can set different voltage limits in synergy and non synergy modes. The voltage setting in synergy is a deviation (plus or minus) of the synergy value. In non synergy mode, the voltage setting is an absolute value. The value set applies to synergy when you are in synergy mode. If you are not in synergy mode, this is an absolute value.

There are also different voltage control limits for short-/sprayarc welding and pulsing in non synergy mode.

Value after resetting

Synergy short-/sprayarc and pulsing	min -10 V	max 10 V
Non synergy short-/sprayarc	min 8 V	max 60 V
Non synergy pulsing	min 8 V	max 50 V

9.3 MIG/MAG defaults

Main menu → Configuration menu → MIG/MAG defaults

In this menu you can set:

- Gun trigger mode (2-stroke/4-stroke)
- 4-stroke configuration
- Soft key configuration
- Voltage measurement in pulsing
- AVC feeder
- “Release pulse”

9.3.1 Gun trigger mode (2-stroke/4-stroke)

2-stroke

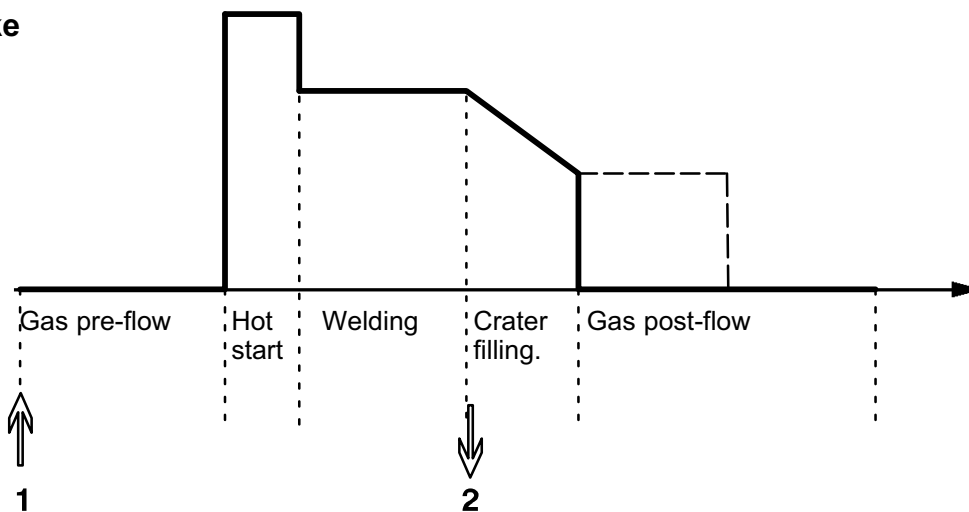

Functions when using 2-stroke control of the welding gun.

Gas pre-flow (if used) starts when the welding gun trigger switch is pressed (1). The welding process then starts. When the trigger switch is released (2), crater filling starts (if selected) and the welding current is stopped. Gas post-flow starts (if selected).

TIP: Pressing the trigger switch again while crater filling is in progress continues crater filling as long as the switch is held depressed (the dotted line). Crater filling can also be interrupted by quickly pressing and releasing the trigger switch while it is in progress.

2-stroke is activated in the measure screen, the configuration menu or with a soft key in the measure screen.

4-stroke

There are 3 start and 2 stop positions for 4-stroke. This is start and stop position 1. When resetting, position 1 is selected. See the chapter 9.3.2 “4-stroke configuration”.

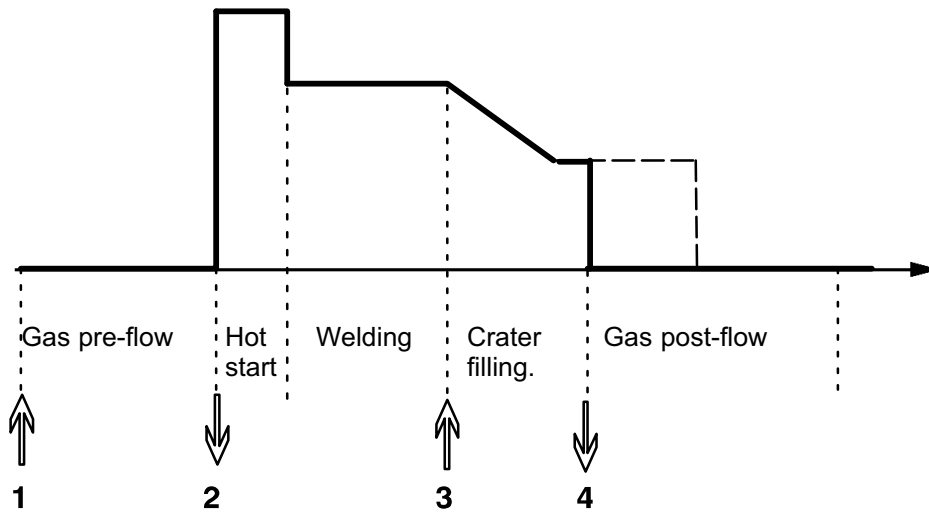

Functions when using 4-stroke control of the welding gun

Gas pre-flow starts when the welding gun trigger switch is pressed (1). Releasing the trigger switch starts the welding process. Pressing the trigger switch again (3) starts crater filling (if selected) and reduces the welding data to a lower value. Releasing the trigger switch (4) stops welding entirely and starts gas post-flow (if selected).

TIP: Crater filling stops when the trigger switch is released. Keeping it held in instead continues crater filling (the dotted line).

4-stroke is activated in the measure screen, the configuration menu or with a soft key in the measure screen.

9.3.2 4-stroke configuration

In 4-stroke configuration, various functions of 4-stroke start and stop can arise.

4-stroke start setting

- Trigger-controlled gas pre-flow, see chapter 9.3.1 “4-stroke”
- Time-controlled gas pre-flow

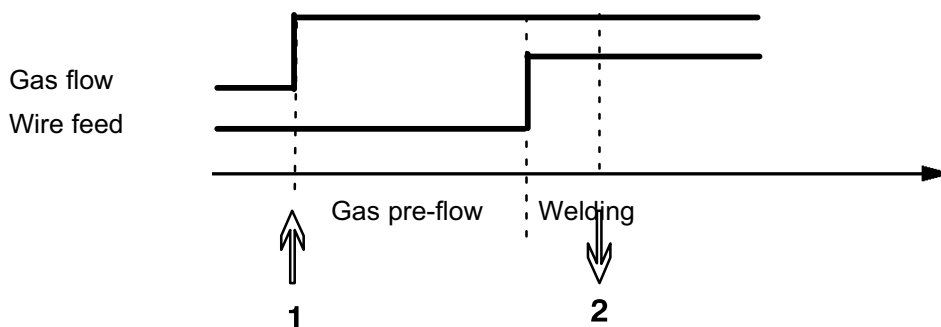

Press in the trigger switch (1), gas pre-flow starts; after the set gas pre-flow time, the welding process starts. Release the trigger switch (2).

- Trigger-controlled hot start

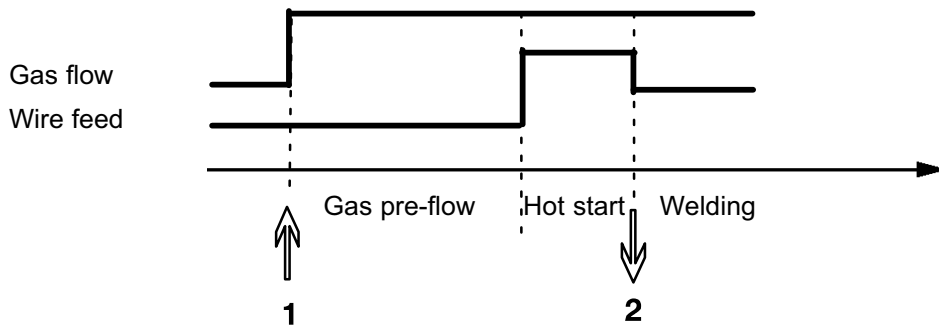

Press in the trigger switch (1); gas pre-flow starts and hot start runs until the switch is released (2).

4-stroke stop setting

- Time-controlled crater filling with possible extension, see chapter 9.3.1 “4-stroke”
- Trigger controlled crater filling time

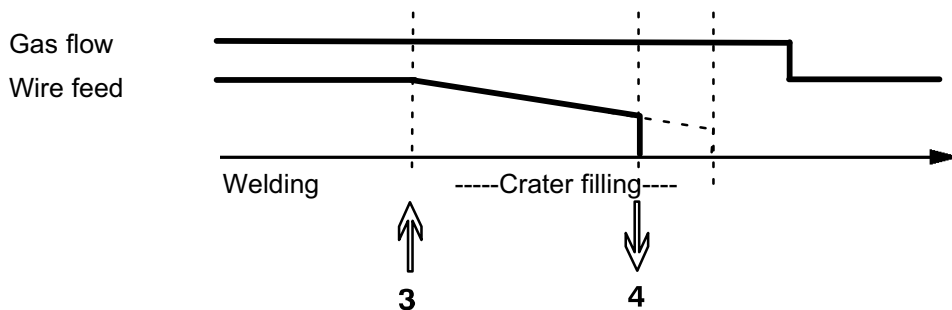

Press in the trigger switch (3); crater filling commences and expires. If the trigger switch is released (4) within the crater filling time (crater filling time shortened), welding is interrupted.

9.3.3 Soft key configuration

We have previously described the control panel's “soft” keys. When MIG/MAG welding, the user has the possibility of setting the function of these keys by selecting from a list of set options. There are seven soft keys that can be allocated a function.

It is possible to choose between the following options:

- None
- Gas purging
- Wire inching
- 2-stroke/4-stroke
- Crater filling ON/OFF
- Creep start ON/OFF
- Hot start ON/OFF
- Weld data switch with gun

In the display screen there are two columns: one for **function** and one for **key number**

SOFT KEYS SETUP	
Function	Soft key
NONE	
GAS PURGE	1
WIRE INCHING	2
TRIGGER MODE (2/4)	3
CRATER FILL ON/OFF	4
CREEP START ON/OFF	5
HOT START ON/OFF	6
TRIGGER SWITCH	7

GAS PURGE	WIRE INCH	4-STROKE	2ND FUNCT	QUIT
-----------	-----------	----------	-----------	------

The panel has five soft keys. By pressing the 2ND FUNCT key you obtain a further five soft keys.

When you allocate functions to these keys, they are numbered from the left as follows

1	2	3	2ND FUNCT	QUIT
4	5	6	7	2ND FUNCT

To allocate a new function to a soft key, proceed as follows:

- Position the cursor on the function row with the function NONE and press the soft key with the function that is to change key number.
- Repeat this procedure with the key that has the key number that is to be used.
- Position the cursor on the function row you want to give a new key number and press the soft key on which you want to have the function.

You can allocate new functions to the other keys in the same way, by pairing together one of the functions in the left-hand column with a key number in the right-hand column.

9.3.4 Voltage measurement in pulsing

Options for voltage methods in pulsing are as follows:

- Peak value in pulse voltage PULSE
The voltage is measured only during the pulse section and filtered before the voltage value is presented on the display.
- Voltage average value AVERAGE
The voltage is measured continuously and filtered before the voltage value is presented.
The measurement values that are presented on the display are used as input data for internal and external quality functions.

9.3.5 AVC feeder

When you have connected an AVC wire feed unit (ARC VOLTAGE CONTROL), go into the CONFIGURATION menu under MIG/MAG BASIC SETTINGS. Press ENTER at the AVC wire feed unit row and select ON. The equipment is then reconfigured automatically to match an AVC wire feed unit.

9.3.6 Release pulse

If the wire becomes trapped in the workpiece, the system detects this. A current pulse is sent out that releases the wire from the surface.

In order to obtain this function, select RELEASE PULSE in the list under MIG/MAG BASIC SETTINGS, then press ENTER and select ON.

9.4 MMA defaults

Main menu → Configuration menu → MMA defaults

Drop welding

Drop welding can be used when welding with stainless electrodes. The function involves alternately striking and extinguishing the arc in order to achieve better control of the supply of heat. The electrode needs only to be raised slightly to extinguish the arc.

Here you can select ON or OFF.

9.5 Fast mode soft keys

The soft keys WELD DATA 1 to WELD DATA 4 are displayed in the fast mode menu. These are configured as follows:

Position the cursor on the SOFT KEY NUMBER row.	FAST MODE SOFT KEYS					
	SOFT KEY NUMBER	1				
	ASSOCIATED WELD DATA	5				
MIG/MAG SHORT/SPRAY SYNERGIC MODE ON Fe, C=2, ..045 + 3.5 VOLT, 300 IN/MIN						
<table border="1" style="width: 100%; border-collapse: collapse;"> <tr> <td style="width: 25%; text-align: center;">STORE</td> <td style="width: 25%; text-align: center;">DELETE</td> <td style="width: 25%;"></td> <td style="width: 25%; text-align: center;">QUIT</td> </tr> </table>			STORE	DELETE		QUIT
STORE	DELETE		QUIT			

The keys are numbered 1-4 from left to right. Select the desired key by specifying its number with the aid of the plus/minus knobs.



Then step down with the left-hand knob to the next row ASSOCIATED WELD DATA. Here you can browse through the weld data sets that are stored in the weld data memory. Select the desired weld data number using the plus/minus knobs. Press STORE to save. To delete the stored set, press DELETE.

9.6 Double start sources

When this option is activated (ON) you can start MIG/MAG welding both from the wire feed unit's start input and from the power source's TIG-start input and vice versa. When welding is started from a start signal input it must be stopped from the same input.

9.7 Panel remote enable

Main menu → Configuration menu → Panel remote enable

Ordinarily you cannot make settings using the pushbuttons when the panel is in remote control mode. When PANEL REMOTE ENABLE is ON, the current/wire feed or voltage can be set using the control panel and remote control.

If PANEL REMOTE ENABLE is used in combination with limits, machine usage can be limited to a specific setting range. This applies to the following settings: wire feed and voltage for MIG/MAG welding, current setting for MMA and TIG welding, pulse current with pulsed TIG.

9.8 Auto save mode

Main menu → Configuration menu → Auto save mode

When a weld data set has been recalled from a memory position in the weld data memory and you change the settings, the changes will be automatically saved in the memory position when you recall a new weld data set from memory.

Saving weld data manually in a memory position disables the next automatic save.

The memory position in which the weld data set is stored is displayed in the top right corner of the measure screen.

9.9 Trigger weld data switch

Main menu → Configuration menu → Trigger weld data switch

This function permits changing to different preset weld data alternatives by double-clicking the welding gun's trigger.

It is possible to change between a maximum of 5 selected memory positions. (See under chapter 8 "Memory management")

OFF - No changeover between weld data.

ARC OFF - The user cannot change between memory positions during welding.

ON - The user can always change between memory positions.



Activating weld data switch

Position the cursor on the TRIGGER WELD DATA SWITCH row and press ENTER. Select OFF, ARC OFF or ON. Press ENTER.

TRIGGER WELD DATA SWITCH	
TRIGGER WELD DATA SWITCH	OFF
ADD/DELETE WELD DATA	5
SELECTED WELD DATA	
MIG/MAG SHORT/SPRAY SYNERGIC MODE ON	
Fe, CO2, 0.045 "	
+ 3.5 VOLT, 300 IN/MIN	
QUIT	

Choice of weld data from memory

Position the cursor on the ADD/DELETE WELD DATA row.

TRIGGER WELD DATA SWITCH		
TRIGGER WELD DATA SWITCH	OFF	
ADD/DELETE WELD DATA	19	
SELECTED WELD DATA 5 19		
MIG/MAG SHORT/SPRAY SYNERGIC MODE OFF		
Fe, CO2, 0.045"		
+ 6 VOLT, 355 IN/MIN		
STORE	DELETE	QUIT

Select the numbers for the memories where current weld data is stored using the plus/minus knobs and then press STORE.

The SELECTED WELD DATA row shows which weld data have been selected and in what order they occur, from left to right. The weld data set for the most recently selected position is displayed under the line in the display.

To remove weld data, follow the same procedure as above but press the DELETE key.

9.10 Multiple wire feeders

Main menu → Configuration menu → Multiple wire feeders

When connecting several wire feed units (max. 4), you have to use wire feed units without a weld data unit, i.e. with an empty panel..

All wire feed units that are supplied to the customer have identity number 1.

The first thing you have to do when connecting several wire feed units is to change the identity number (node address) of one wire feed unit.

To change the ID number, proceed as follows:

- Connect the first wire feed unit, go to the MULTIPLE WIRE FEEDERS menu.
- Press and release the trigger switch to activate the wire feed unit.
- Then read on the first row which ID number the wire feed unit has (should be 1 the first time). Then select a new ID number between 2 and 4.

Position the cursor on the SELECT A NEW ID NUMBER row. Set the desired number between 1 and 4 by stepping with the plus/minus knobs. Press ENTER.

MULTIPLE WIRE FEEDERS	
CURRENT ID NUMBER	-
SELECT A NEW ID NUMBER	1
CONNECTED WIRE FEEDERS ID:	
QUIT	

On the top row, the figure for the ID number will change to the desired number.

- Connect the next wire feed unit.
- Press and release the trigger switch to activate this wire feed unit. You can now see that the unit has ID number 1.

Configuration is now complete and you can start using the equipment as normal. In the same way it is possible to configure and run four wire feed units. The important thing when using several wire feed units is not which ID number they have been given, but that they are given different numbers in order that they can be distinguished.

Take care not to give the same ID to two wire feed units. If this should occur, rectify the situation by disconnecting one of the units and then starting the above procedure again from the beginning. You can always go to the “MULTIPLE WIRE FEEDERS” menu and check the ID number of the connected wire feed units by pressing the trigger switch.

On the CONNECTED WIRE FEEDERS ID row, you can see the ID number of all connected wire feed units.

9.11 Quality functions

Main menu → Configuration menu → Quality functions

The conditions for logging completed welds are set under Quality functions in the Configuration menu.

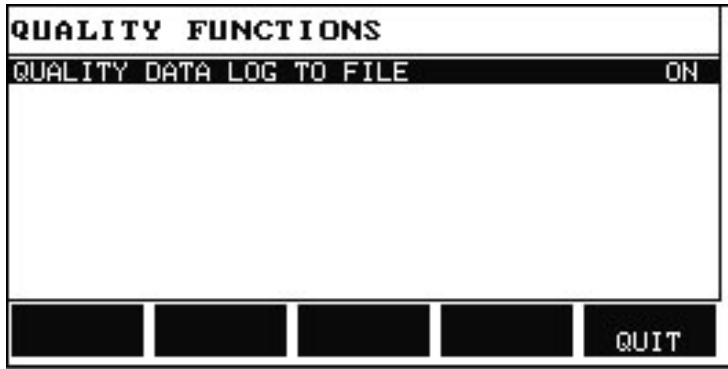

Select the row and press ENTER. If ON is selected, each weld will be stored as a text file with the extension .aqd, with a new file per day. The following information is registered here:

- Time of welding start
- Duration of welding
- Maximum, minimum and average current during welding
- Maximum, minimum and average voltage during welding
- Maximum, minimum and average output during welding

Read more about the quality function in chapter [10.7](#).

9.12 Maintenance

Main menu → Configuration menu → Maintenance

In this menu you set how often the contact tip is to be changed. Specify the number of weld starts after which the tip is to be changed by selecting the CONTACT TIP CHANGE INTERVAL row and pressing ENTER. Then adjust the plus/minus knobs until you arrive at your value. When the interval has been passed, fault code 54 is displayed in the error log. Reset by pressing the RESET soft key.

When TOTAL RUNNING TIME LIMIT is selected instead of the number of starts, an authorised ESAB service technician is contacted.

SERVICE	
CONTACT TIP CHANGE INTERVAL	0 Welds
WELD COUNT	0 Welds
TOTAL RUNNING TIME LIMIT	0d00:00:00
TOTAL RUNNING TIME	0d00:00:00

RESET | | | | QUIT

9.13 Measure value frequency

Main menu → Configuration menu → Measure value frequency

The frequency of the measurement value is set here by stepping to a value between 1 and 10 Hz using one of the plus/minus knobs.

9.14 Register key

Main menu → Configuration menu → Register key

With the function REGISTER KEY you can unlock certain functions, which are not included in the basic version of the control panel. For information regarding these functions, see page 77.

In order to get access to these functions you have to contact ESAB. When you indicate the serial number of the unit you will get a key code, which is to be entered in the menu REGISTER KEY.

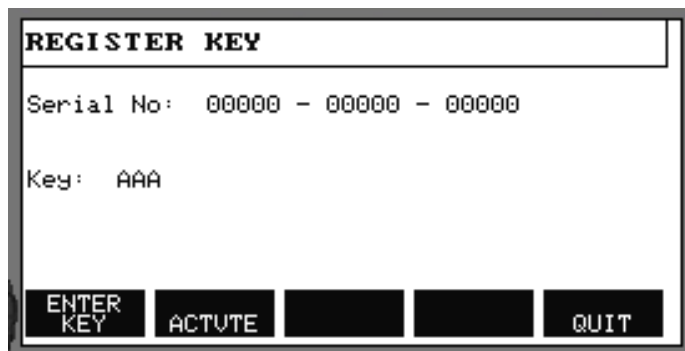

Press ENTER KEY and write the key code on the keyboard, which appears in the display. Position the cursor on the desired keyboard character using the left-hand knob and the arrow keys. Press ENTER. When the character string is registered, press DONE.

To activate the key press ACTVTE. A message will be shown: KEY ACTIVATED. If the registration was unsuccessful, the message will be: INCORRECT KEY. Then check the key code and try again.

10 TOOLS

Main menu → Tools

This menu contains the following sub-menus:

- Error log, see chapter [10.1](#).
- Export/Import, see chapter [10.2](#).
- File manager, see chapter [10.3](#).
- Edit setting limits, see chapter [10.4](#).
- Edit measurement value settings, see chapter [10.5](#).
- Production statistics, see chapter [10.6](#).
- Quality functions, see chapter [10.7](#).
- User defined synergic data, see chapter [10.8](#).
- Calendar, see chapter [10.9](#).
- User accounts, see chapter [10.10](#).
- Unit information, see chapter [10.11](#).

10.1 Error log

Main menu → Tools → Error log

Fault management codes are used to indicate that a fault has occurred in the welding process. This is specified in the display with the aid of a popup menu. An exclamation mark  appears in the top right corner of the display.

Note!  disappears from the display as soon as you go into the error log menu.

All errors that arise during the use of the welding equipment are documented as error messages in the error log. Up to 99 error messages can be saved. If the error log becomes full, i.e. if 99 error messages have been saved, the oldest message is automatically deleted when the next fault occurs.

The following information can be read in the error log menu:

- The error number of the error
- The date on which the error has occurred
- The time at which the error has occurred
- The unit in which the error has occurred
- The error's error management code

ERROR LOG					
Index	Date	Time	Unit	Error	
1	080917	11:24:13	8	19	
2	080918	10:24:18	8	17	
Lost contact with wire feeder					
DELETE		DELETE ALL	UPDATE	VIEW TOTAL	QUIT

10.1.1 Units

- | | |
|--------------------|-------------------------|
| 1 = cooling unit | 4 = remote control unit |
| 2 = power source | 5 = AC-unit |
| 3 = wire feed unit | 8 = control panel |

10.1.2 Error code descriptions

The fault management codes that users can correct themselves are given below. If a different code appears, call a service technician.

Error code	Description
1	<p>Program memory error (EPROM)</p> <p>The program memory is damaged.</p> <p>This error does not disable any functions.</p> <p>Action: Restart the machine. If the error persists, send for a service technician.</p>
2	<p>Microprocessor RAM error</p> <p>The microprocessor is unable to read/print to the internal memory.</p> <p>This error does not disable any functions.</p> <p>Action: Restart the machine. If the error persists, send for a service technician.</p>
3	<p>External RAM error</p> <p>The microprocessor is unable to read/print to the external memory.</p> <p>This error does not disable any functions.</p> <p>Action: Restart the machine. If the error persists, send for a service technician.</p>

Error code	Description
4	<p>5 V power supply low</p> <p>The power supply voltage is too low.</p> <p>The current welding process is stopped and starting is prevented.</p> <p>Action: Turn off the mains power supply to reset the unit. If the error persists, send for a service technician.</p>
5	<p>Intermediate DC voltage outside limits</p> <p>The voltage is too high or too low. Too high a voltage can be due to severe transients on the mains power supply or to a weak power supply (high inductance of the supply or a phase missing).</p> <p>The power unit is stopped and cannot be started.</p> <p>Action: Turn off the mains power supply to reset the unit. If the error persists, send for a service technician.</p>
6	<p>High temperature</p> <p>The thermal overload cut-out has tripped.</p> <p>The current welding process is stopped and cannot be restarted until the cut-out has reset.</p> <p>Action: Check that the cooling air inlets or outlets are not blocked or clogged with dirt. Check the duty cycle being used, to make sure that the equipment is not being overloaded.</p>
7	<p>High primary current</p> <p>The power unit takes too much current from the DC voltage that supplies it.</p> <p>The power unit is stopped and cannot be started.</p> <p>Action: Turn off the mains power supply to reset the unit. If the error persists, send for a service technician.</p>
12	<p>Communication error (warning)</p> <p>The load on the system's CAN-bus is temporarily too high.</p> <p>The power unit / wire feed unit has lost contact with the control panel.</p> <p>Action: Check that all the equipment is correctly connected. If the error persists, send for a service technician.</p>
14	<p>Communication error</p> <p>The system's CAN-bus has temporarily stopped working due to the load being too high.</p> <p>The current welding process stops.</p> <p>Action: Check that all the equipment is correctly connected. Turn off the mains power supply to reset the unit. If the error persists, send for a service technician.</p>
15	<p>Messages lost</p> <p>The microprocessor is unable to process incoming messages sufficiently quickly and information has been lost.</p> <p>Action: Turn off the mains power supply to reset the unit. If the fault persists, send for a service technician.</p>
17	<p>Lost contact with an other unit</p> <p>The current activities will be stopped and the welding start is prevented.</p> <p>This error can be caused by a break in the connection (i.e. the CAN cable) between the welding data unit and an other unit. Which unit it concerns is displayed in the error log.</p> <p>Action: Check the CAN cabling. If the error persists, send for a service technician.</p>

Error code	Description
19	<p>Memory error in battery powered data memory RAM</p> <p>The battery has lost voltage</p> <p>Action: Turn off the mains power supply to reset the unit. The control panel is reset. The settings are in English, with MIG/MAG, SHORT/SPRAY, Fe, CO2, 1.2 mm. If the error persists, send for a service technician.</p>
22	<p>Transmitter buffer overflow</p> <p>The control panel does not manage to transmit information to the other units sufficiently quickly.</p> <p>Action: Turn off the mains power supply to reset the unit.</p>
23	<p>Receiver buffer overflow</p> <p>The control panel does not manage to process information from the other units sufficiently quickly.</p> <p>Action: Turn off the mains power supply to reset the unit.</p>
25	<p>Incompatible weld data format</p> <p>Attempt to store weld data on a USB memory. The USB memory has a different data format than the weld data memory.</p> <p>Action: Use a different USB memory.</p>
26	<p>Program error</p> <p>Something has prevented the processor from performing its normal tasks in the program.</p> <p>The program restarts automatically. The current welding process will be stopped. This fault does not disable any functions.</p> <p>Action: Review the handling of welding programs during welding. If the error is repeated, send for a service technician.</p>
28	<p>Program data lost</p> <p>Program execution does not work.</p> <p>Action: Turn off the mains power supply to reset the unit. If the error persists, send for a service technician.</p>
40	<p>Incompatible units</p> <p>Incorrect wire feed unit is connected. Start prevented.</p> <p>Action: Connect the correct wire feed unit.</p>
54	<p>Service interval passed</p> <p>The service interval for changing the contact tip has passed.</p> <p>Action: Replace contact tip</p>
60	<p>Communication error</p> <p>The system's internal CAN-bus has temporarily stopped working due to the load being too high. The current welding process stops.</p> <p>Action: Check that all the equipment is correctly connected. Turn off the mains power supply to reset the unit. If the error persists, send for a service technician.</p>
64	<p>Measurement value limit passed</p> <p>The measurement values have exceeded their limits.</p> <p>Action: Check that the limit is correctly set as well as the quality of the joint.</p>

10.2 Export/Import

Main menu → Tools → Export/Import

In the Export/Import menu, it is possible to transfer information to and from the control panel via a USB memory.

The following information can be transferred:

- Weld data sets Export/Import
- System settings ”
- Setting limits ”
- Measure limits ”
- Error log Export
- Quality function log ”
- Production statistics ”
- Synergic lines Export/Import
- Basic settings “

Insert the USB memory. See chapter 2.3 for a description of how to insert the USB memory . Select the row with the information that is to be transferred. Press EXPORT or IMPORT, depending on whether the information is to be exported or imported.

EXPORT/IMPORT				
WELD DATA SETS				
SYSTEM SETTINGS				
SETTING LIMITS				
MEASURE LIMITS				
ERROR LOG				
QUALITY FUNCTION LOG				
PRODUCTION STATISTICS				
SYNERGIC LINES				
BASIC SETTINGS				
EXPORT	IMPORT			QUIT

10.3 File manager

Main menu → Tools → File manager

In file manager you can process information both in a USB memory (C:\). File manager makes it possible to delete and copy weld data and quality data manually.

When the USB memory is inserted, the display shows the basic folder of the memory if no folder already has been chosen.

The control panel remembers where you were the last time you used file manager, so that you return to the same place in the file structure when you come back.

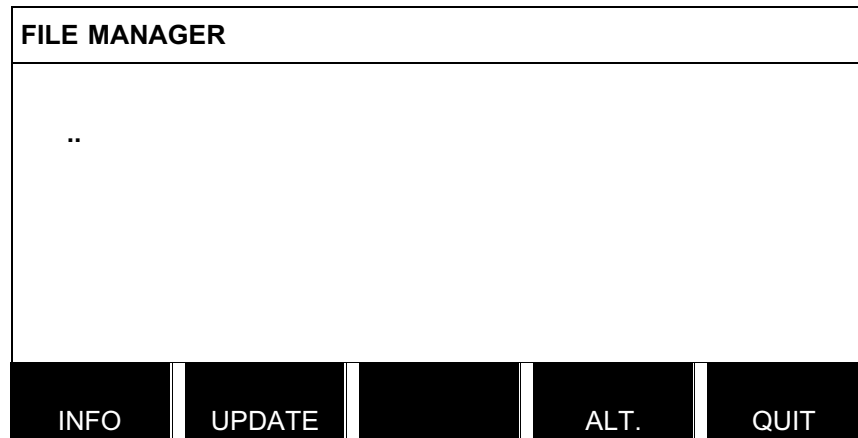

In order to ascertain how much storage space remains for the memory, use the INFO function.

Update the information by pressing UPDATE.

When you want to delete, change name, create new folder, copy or paste, press ALT. A list then appears from which you can choose. If (..) or a folder is selected, you can only create a new folder or paste in a file that you have previously copied. If you have selected a file, the options RENAME, COPY or PASTE will be added if you have previously copied a file.

Select a folder or file and press ALT.

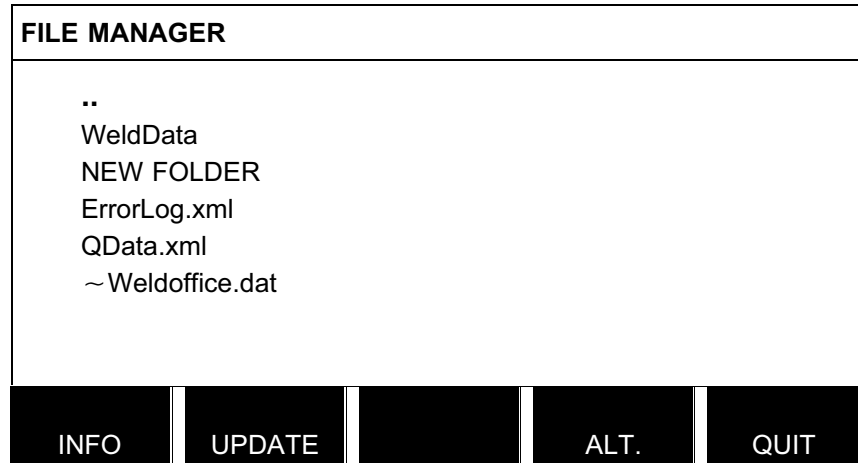

This list is displayed when you have pressed ALT.

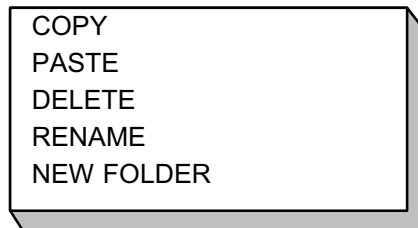

10.3.1 Delete a file/folder

Select the file or folder that is to be deleted and press ALT.

Select DELETE and press ENTER.



The file/folder is now removed. In order to delete a folder it must be empty, i.e. first delete the files contained in the folder.

10.3.2 Rename a file/folder

Select the file or folder that is to be renamed and press ALT.

Select RENAME and press ENTER.



A keyboard appears in the display. Use the knob to the left to change row and the arrow keys to move left and right. Select the character/function that is to be used and press ENTER.

10.3.3 Create new folder

Select where the new folder is to be located and press ALT.

Select NEW FOLDER and press ENTER.



A keyboard then appears in the display. Use the knob to the left to change row and the arrow keys to move left and right. Select the character/function that is to be used and press ENTER.

10.3.4 Copy and paste files

Select the file that is to be copied and press ALT.

Select COPY and press ENTER.

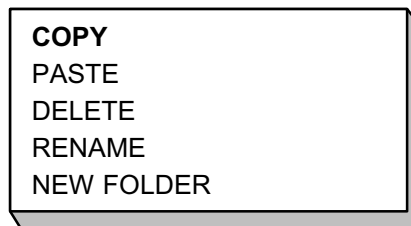

Position the cursor in the folder in which the copied file is to be located and press ALT.

Select PASTE and press ENTER.

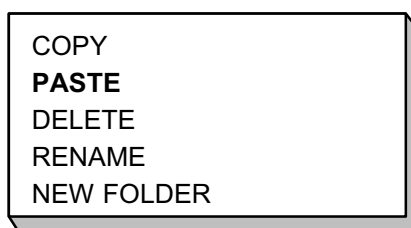

The copy is saved as Copy of plus the original name, e.g. Copy of WeldData.awd.

10.4 Edit setting limits

Main menu → Tool → Edit setting limits

In this menu you set your own max. and min. values for various welding methods. The limits cannot be above or below the values for which the power source is dimensioned. There are 50 storage points. Select the row for an empty storage point and press ENTER. Select process (MIG/MAG, MMA, TIG) and press ENTER. For MIG/MAG, the max. and min. values for voltage and wire feed speed can be selected.

EDIT SETTING LIMITS	
PROCESS	MIG/MAG
VOLTAGE	
- MIN	8.0 V
- MAX	60.0 V
WIRE SPEED	
- MIN	31 IN/MIN
- MAX	984 IN/MIN
STORE	AUTO
DELETE	QUIT

For MMA and TIG, the max. and min. values for current can be changed.

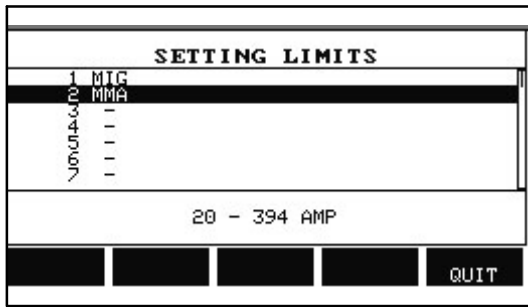

When the values have been adjusted, press STORE. When asked if the limit value is to be saved at the selected storage point, press NO or YES. The storage point's values can be seen under the line at the bottom. In this case, storage point 2 for the MMA limit values is 20 - 394 A.

With AUTO, the limits are set automatically according to the limits that have been set for each welding method.

When asked if the setting limits are to be set automatically, press NO or YES and then STORE if the setting is to be retained.

10.5 Edit measure limits

Main menu → Tools → Edit measure limits

In this menu you set your own measurement values for the various welding methods. There are 50 storage points. Select the row for an empty storage point and press ENTER. Select process by pressing ENTER. Then select welding process from the list that appears and then press ENTER again.

The following values can be selected:

For MIG/MAG

- voltage: min., max., min. average, max. average
- current: min., max., min. average, max. average
- output: min., max., min. average, max. average
- wire feed unit current: min., max., min. average, max. average

Tip: To prevent feed problems, especially when robot welding, it is recommended that a max value is given for the feed unit motor current. High motor current indicates feed problems. To give the correct max value it is recommended that the motor current be studied during a month's welding. Then a suitable maximum value is given.

For MMA and TIG

- voltage: min., max., min. average, max. average
- current: min., max., min. average, max. average
- output: min., max., min. average, max. average

Set the desired value with one of the right-hand knobs and press STORE.

In the dialogue box, you are asked if you want to store the selected storage point. Press YES to save the value. The storage point's values can be seen under the line at the bottom.

MEASURE LIMITS				
1 - MIG				
2 - TIG				
3 -				
4 -				
5 -				
6 -				
7 -				
24.0 - 34.0 VOLT, 90 - 120 AMP 2000 - 3000 Kw				
				QUIT

With AUTO, the limits are set automatically according to the most recently used measurement values.

When asked if the measurement values are to be set automatically, press NO or YES and then STORE if the setting is to be retained.

10.6 Production statistics

Main menu → Tools → Production statistics

The production statistics will keep track of the total arc time, the total amount of material and the number of welds since the most recent reset. They will also keep track of the arc time and the amount of material used in the most recent weld. For information purposes, the melted wire material per length unit that has been calculated and when the most recent reset occurred are also displayed.

The number of welds does not increase if the arc time has been shorter than 1 second. For this reason, the amount of material used for a short weld of this type is not displayed. However, material consumption and time are included in the total material consumption and time.

PRODUCTION STATISTICS		
	LAST WELD	TOTAL
ARC TIME	0s	0s
CONSUMED WIRE	0g	0g
BASED ON	0g/m	
NUMBER OF WELDS		0
LAST RESET	081114	08:38:03
RESET	UPDATE	QUIT



When you press RESET, all counters are reset. Date and time show the most recent reset.

If you do not reset the counters, these are all automatically reset when one of them has reached its maximum value.

Maximum counter values

Time 999 hours, 59 minutes, 59 seconds
Weight 13350000 grams
Quantity 65535

Material consumption is not counted when using customer specific synergy lines.

10.7 Quality functions

Main menu → Tools → Quality functions

Quality functions keep track of various interesting weld data for individual welds.

These functions are:

- Time of welding start.
- Duration of welding.
- Maximum, minimum and average current during welding.
- Maximum, minimum and average voltage during welding.
- Maximum, minimum and average output during welding.

In order to calculate the heat input, the selected weld is highlighted. Browse between the welds with the upper right-hand knob (#) and adjust the length of the joint with the lower knob (*). Press UPDATE and the welding unit calculates the heat input for the selected weld.

The number of welds since the most recent reset is displayed in the row at the bottom. Information can be stored about a maximum of 100 welds. In the event of more than 100 welds, the first one is overwritten. Welding must last for longer than one second to be registered.

The most recently noted weld is presented in the display, although it is also possible to browse between other noted welds. All logs are deleted when you press RESET.

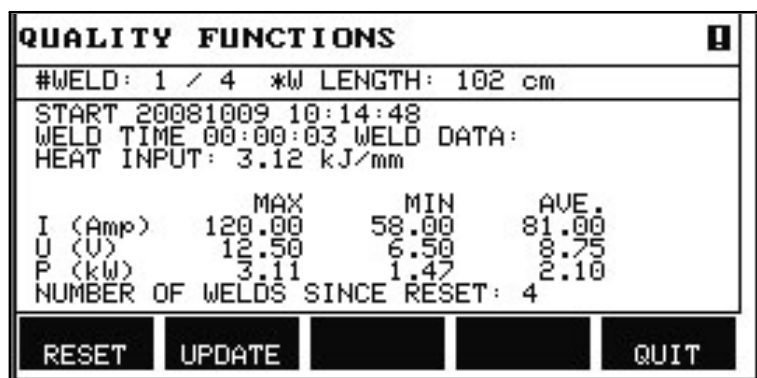

Description of welding data schedule

Each welding data schedule can have a short description. Under the SET menu and EDIT DESCRIPTION, the welding data schedule that has just been called up can be given a description of max. 40 characters via the integral keyboard. The current description can also be modified or deleted.

If the requested schedule has a description, this is shown in the MEMORY, MEASURE and REMOTE menu screens instead of the welding data parameters which are otherwise displayed.

10.7.1 Store quality data

Main menu → Tools → Export/Import

The files that are produced in the control panel are stored as xml files. The USB memory must be formatted as FAT in order to work. The control panel can be used with ESAB's WeldPoint software, which is ordered separately.

Insert a USB memory in the control panel, see chapter 10.3 “File manager”.

Select QUALITY FUNCTION LOG, press EXPORT.

EXPORT/IMPORT				
WELD DATA SETS				
SYSTEM SETTINGS				
SETTING LIMITS				
MEASURE LIMITS				
ERROR LOG				
QUALITY FUNCTION LOG				
PRODUCTION STATISTICS				
SYNERGIC LINES				
BASIC SETTINGS				
EXPORT				QUIT

The entire set of quality data (information about the 100 most recent welds) that is stored in the control panel is now saved on the USB memory.

The file is in a folder called QData. QData is created automatically when you insert a USB memory.

10.8 User defined synergic data

Main menu → Tools → User defined synergic data

It is possible to create your own synergic lines with respect to wire feed speed and voltage. A maximum of ten such synergic lines can be saved.

A new synergic line is created in two steps:

1. Define the new synergic line by specifying a number of voltage/wire speed co-ordinates, see points A-D in the following figure:

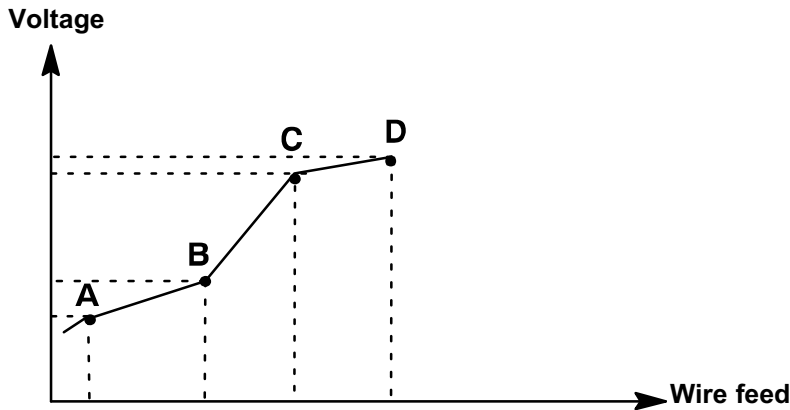

2. Specify the wire/gas combination to which the synergic line is to apply.

10.8.1 Specify voltage/wire co-ordinates

In order to create a synergic line for the **short-/sprayarc** method, four co-ordinates are required; for the **pulsing** method, two co-ordinates are required. These co-ordinates must then be saved under separate weld data numbers in the weld data memory.

Short-/Sprayarc

- Bring up the main menu and select the MIG/MAG method SHORT/SPRAY.
- Key in the desired values for voltage and wire feed speed for the first co-ordinate.
- Bring up the MEMORY menu and store the first co-ordinate on any number.
 - The four co-ordinates for a short-/sprayarc line can be saved as any numbers. When supplied from the factory, they are saved as numbers 96, 97, 98 and 99.

A higher weld data number should contain higher values for voltage and wire feed speed than the nearest preceding weld data number.

The welding parameters inductance and regulator type must have the *same value* in all four weld data numbers.

- Define the number of co-ordinates that are required and then proceed to chapter [10.8.2](#) "Specify valid wire/gas combination".

Pulsing

- Bring up the main menu and select the MIG/MAG method PULSING.
- Key in the desired values for voltage and wire feed speed for the first co-ordinate.
- Bring up the MEMORY menu and store the first co-ordinate on any number.
 - A higher weld data number should contain higher values for voltage, wire feed speed, pulse frequency, pulse amplitude and background current than the nearest preceding weld data number.

The welding parameters pulse time, Ka, Ki and “slope” must have the *same value* in both weld data numbers.

- Define the number of co-ordinates that are required and then proceed to chapter [10.8.2](#) “Specify valid wire/gas combination”.

10.8.2 Specify valid wire/gas combination

Position the cursor on the WIRE TYPE row and press ENTER.

MAKE CUSTOMISED SYNERGIC LINES	
WIRE TYPE	Fe
SHIELDING GAS	CO2
WIRE DIMENSION	0.023”
SYNERGIC DESIGN SCHEDULE 1	96
SYNERGIC DESIGN SCHEDULE 2	97
SYNERGIC DESIGN SCHEDULE 3	98
SYNERGIC DESIGN SCHEDULE 4	99

STORE
DELETE

QUIT

Select an alternative that is displayed in the list and press ENTER.

Fe
Ss 18%Cr 8%Ni
Ss duplex
Al Mg
Al Si
Metal cored Fe

Select in the same way for SHIELDING GAS and press ENTER.

CO2
Ar 18%CO2
Ar2%O2
Ar
He
ArHeO2

Select in the same way for WIRE DIAMETER and press ENTER.



Select the SYNERGIC DESIGN SCHEDULE 1 row and press STORE.

The operation is now complete – a synergic line has been defined.

NOTE! A corresponding short-/sprayarc synergy is needed for each pulsing instance.

When you create a new synergic line for the pulsing method, you therefore always receive a warning message stating that a corresponding line has not been created for the short-/sprayarc method. The message reads: *WARNING! No corresponding synergic line for short-/sprayarc.*

10.8.3 Create your own wire/gas alternative

The lists of wire/gas alternatives can be extended with up to ten alternatives of your own. At the bottom of each list there is a blank row (---). By positioning the cursor on this row and pressing ENTER, you gain access to a keyboard that enables you to enter your own alternatives.

Select the row --- and press ENTER.

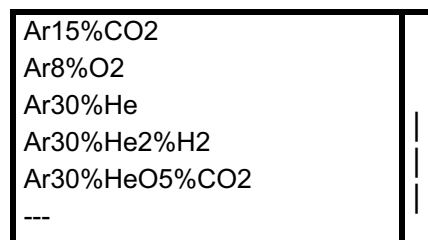

The control panel's keyboard is used as follows:

- Position the cursor on the desired keyboard character using the left-hand knob and the arrow keys. Press ENTER. Enter a complete character string with a maximum of 16 characters in this way.
- Press DONE. The alternative you have named can be seen in the list.



Delete a named alternative as follows:

- Select your own wire/gas alternative from the relevant list.
- Press DELETE.

NOTE! A named wire/gas alternative *cannot be deleted* if it is included in the weld data set that is currently in the working memory.

10.9 Calendar

Main menu → Tools → Calendar

Date and time are set here.

Select the row that is to be set: year, month, day, hour, minutes and seconds. Set the correct value using one of the right-hand knobs. Press SET.

DATE & TIME	
YEAR	2008
MONTH	OCT
DAY	06
HOUR	08
MINUTES	11
SECONDS	26
20081006 08:11:47	
<div style="display: flex; justify-content: space-between;"> SET QUIT </div>	

10.10 User accounts

Main menu → Tools → User accounts

Occasionally it is particularly important from a quality perspective that the power source cannot be used by unauthorised parties.

User name, account level and password are registered in this menu.

Select USER NAME and press ENTER. Step down to an empty row and press ENTER. Key in a new user name on the keyboard using the left-hand knob, the right and left arrows and ENTER. There is space for 16 user accounts. In the quality data files it will be evident which users have executed a particular weld.

USER ACCOUNTS	
USER NAME	ADMINISTRATOR
ACCOUNT LEVEL	ADMIN
USER PASSWORD	
USER ACCOUNTS	OFF
<div style="display: flex; justify-content: space-between;"> STORE DELETE QUIT </div>	

Under ACCOUNT LEVEL choose from:

- Administrator
full access (can add new users)
- Senior user
can access everything except:
 - code lock
 - multiple wire feeders
 - calendar
 - user accounts
- Normal user
can access the measure menu

In the USER PASSWORD row, key in a password using the keyboard. When the power source is switched on and the control panel activated, you are asked in the display to enter your password.

If you choose not to have this function, but instead want the power source and control panel to be unlocked for all users, select USER ACCOUNTS OFF.

10.11 Unit information

Main menu → Tools → Unit information

In this menu you can see the following information:

- Machin ID
- Node ID
 - 2 = power source
 - 3 = wire feed
 - 8 = control panel
- Software version

UNIT INFORMATION		
Machine ID	Node ID	Software Version
44	8	1.00A
23	2	2.00 A
5	3	1.18A
WELD DATA UNIT		
		QUIT

11 ORDERING SPARE PARTS

When ordering replacement parts, order by part number and part name, as illustrated on the figure. Always provide the series or serial number on the unit on which the parts will be used. The serial number is stamped on the rating plate.

Menu structure

MIG/MAG

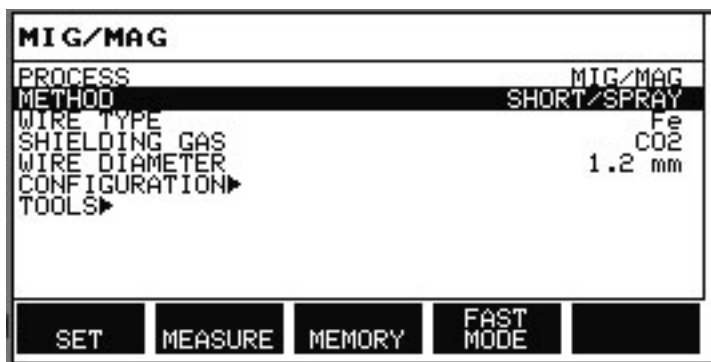

Process
Method
Phase - Method
Wire type
Shielding gas
Wire diameter
Configuration
Tools

Short/Spray

Pulse

Superpulse

Qset

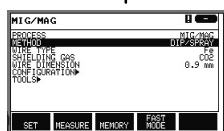

SET

Voltage
Wire speed
Inductance
Control type
Synergic Mode
Start data
- gas preflow
- creep start
- hot start
- touch sense
Stop data
- crater fill
- pinch off pulse
- burn back time
- gas postflow
Setting limits
Measure limits
Spot welding
Edit description

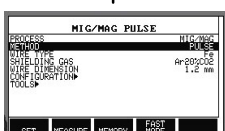

SET

Voltage
Wire speed
Pulse current
Pulse time
Pulse frequency
Background current
Slope
Synergic Mode
Internal constants
-Ka
-Ki
Start data
- gas preflow
- creep start
- hot start
- touch sense
Stop data
- crater fill
- burn back time
- gas postflow
Setting limits
Measure limits
Spot welding
Edit description



SET

Voltage
Wire speed
Pulse current
Pulse time
Pulse frequency
Background current
Slope
Inductance
Control type
Synergic Mode
Phase weldtime
Internal constants
-Ka
-Ki
Start data
- gas preflow
- creep start
- hot start
- touch sense

Stop data
- crater fill
- pinch off pulse
- burn back time
- gas postflow
Setting limits
Spot welding
Edit description



SET

Wire speed
Inductance
Control type
Start data
-gas preflow
-creep start
Stop data
-pinch off pulse
-burn back time
-gas post flow
Setting limits
Measure limites
Spot welding
Edit description

MMA

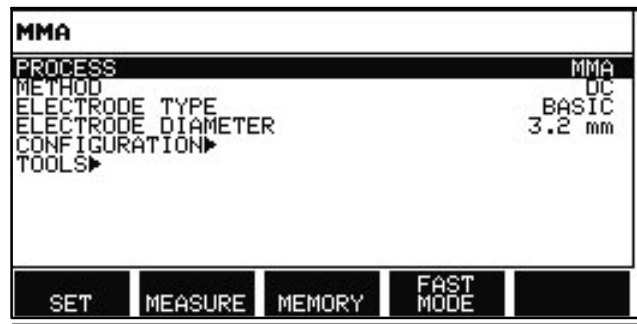

Process
Method
Electrode type
Electrode diameter
Configuration
Tools

* Not implemented yet

MMA DC

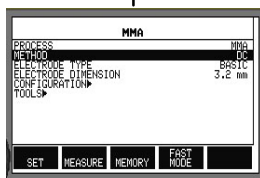

Current
Arc Force
Min current factor
Control type
Synergic mode
Hot start
Setting limits
Measure limits
Edit description

MMA AC *

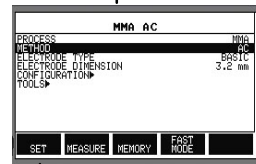

Current
Arc force
Min current factor
Control type
Synergic mode
Hot start
- hot start duration
- hot start amplitude
Setting limits
Measure limits
Edit description

TIG

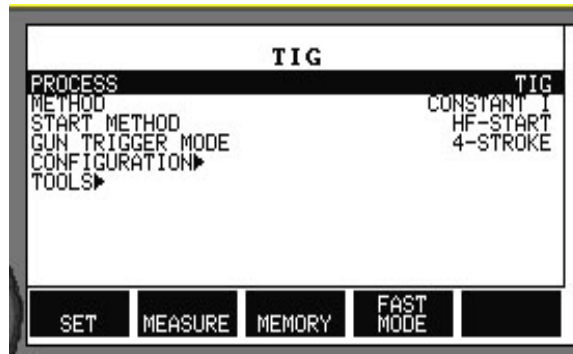

Process
Method
Start method
Gun trigger mode
Configuration
Tools

* Not implemented yet

TIG Constant I

TIG Pulsed I

TIG Constant AC*

TIG Pulsed AC*

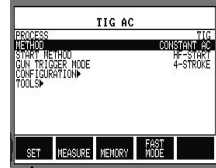
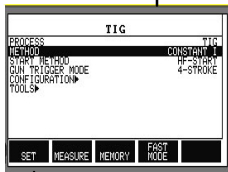

SET

SET

SET

SET

Current
Slope up time
Slope down time
Gas preflow
Gas postflow
Setting limits
Measure limits
Edit description

Current
Background current
Pulse time
Background time
Slope up time
Slope down time
Gas preflow
Gas postflow
Setting limits
Measure limits
Edit description

Current
Slope up time
Slope down time
Gas preflow
Gas post flow
Preheating
Frequency
Balance
Offset
Setting limits
Measure limits
Edit description

Current
Slope up time
Slope down time
Gas preflow
Gas post flow
Preheating
Frequency
Balance
Offset
Pulse periods
Background current
Background periods
Background balance
Background frequency
Background offset
Setting limits
Measure limits
Edit description

GOUGING

GOUGING	
PROCESS	GOUGING
ELECTRODE DIAMETER	5 mm
CONFIGURATION▶	
TOOLS▶	
SET	MEASURE
MEMORY	FAST MODE

Process
Electrode diameter
Configuration
Tools

SET

Voltage
Synergic mode
Inductance
Control type
Edit description

CONFIGURATION - TOOLS

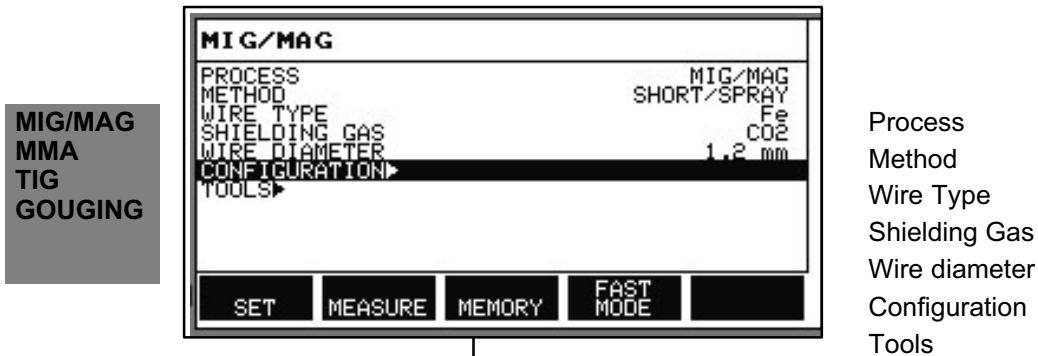

Configuration

Tools

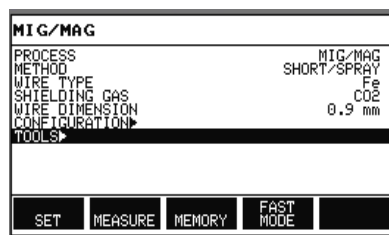
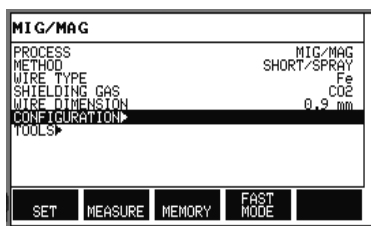

- Language
- Code lock
- Remote controls
- MIG/MAG defaults
- gun trigger mode
- 4-stroke configuration
- soft keys configuration
- volt.measure in pulsed
- AVC feeder
- release pulse
- MMA defaults
- droplet welding
- Fast mode soft buttons
- Double start sources
- Panel remote enable
- Auto save mode

- Trigger welddata switch
- Multiple wire feeders
- Quality functions
- Maintenance
- Unit of length
- Measure value frequency
- Register key
- Error category config

- Error log
- Export/import
- weld data sets
- system settings
- setting limits
- measure limits
- error log
- quality function log
- production statistics
- synergic lines
- basic settings
- File manager
- Setting limit editor
- Measure limit editor
- Production statistics
- Quality functions
- User defined synergic data
- Calendar
- User accounts
- Unit information

Functional differences

Functions	U8₂ Basic	U8₂ Plus
Super Pulse	No	Yes
Limit editor	Yes	Yes
File manager	No	Yes
Auto save mode	No	Yes
Release pulse	Yes	Yes
Synergic lines	Basic package = 92 lines	Complete no of available lines
User defined synergic data	No	Yes
Production statistics	No	Yes

Wire and gas dimensions

U8₂ Basic - MIG/MAG welding with SHORT-/SPRAYARC

Wire type	Shielding gas	Wire diameter (inch)
Low alloy or unalloyed wire (Fe)	CO ₂	.030 .040 .047 1/16*
	Ar + 18% CO ₂	.030 .040 .047 1/16*
	Ar + 8% CO ₂	.030 .040 .047 1/16*
	Ar + 23% CO ₂	.030 .040 .047 1/16*
Stainless solid wire (Ss)	Ar + 2% O ₂	.030 .040 .047 1/16*
	Ar + 2% CO ₂	.030 .040 .047 1/16*
Magnesium-alloyed aluminium wire (AlMg)	Ar	.040 .047 1/16*
Silicon-alloyed aluminium wire (AlSi)	Ar	.040 .047 1/16*
	Ar + 50% He	.040 .047 1/16*
Metal powder cored wire (Fe)	Ar + 18% CO ₂	.047 1.4* 1/16*
	Ar+ 8% CO ₂	.047 1.4* 1/16*
Rutile flux cored wire (Fe)	Ar + 18% CO ₂	.047 1.4* 1/16*
Basic flux cored wire (Fe)	CO ₂	.047 1.4* 1/16*
	Ar + 18% CO ₂	.047 1.4* 1/16*
Metal powder cored stainless wire (Ss)	Ar + 8% CO ₂	.047
	Ar + 2% O ₂	.047
	Ar + 18% CO ₂	.047
	Ar + 2% CO ₂	.047
Silicon bronze (CuSi3)	Ar	.040 .047
	Ar + 1% O ₂	.040 .047

*) Only for Mig 4000i, 4001i, 4502c, 5000i, 5002c, 6502c

U8₂ Basic - MIG/MAG welding with PULSE

Wire type	Shielding gas	Wire diameter (mm)
Low alloy or unalloyed wire (Fe)	Ar + 18% CO ₂	.040 .047 1/16*
	Ar + 8% CO ₂	.040 .047 1/16*
Stainless wire (Ss)	Ar + 2% O ₂	.030 .040 .047 1/16*
	Ar + 2% CO ₂	.030 .040 .047 1/16*
Magnesium-alloyed aluminium wire (AlMg)	Ar	.040 .047 1/16*
Silicon-alloyed aluminium wire (AlSi)	Ar	.040 .047 1/16*
	Ar + 50% He	.040 .047 1/16*
Metal powder cored wire (Fe)	Ar + 18% CO ₂	.047 1.4* 1/16*
	Ar + 8% CO ₂	.047 1.4* 1/16*
Metal powder cored stainless wire (Ss)	Ar + 2% O ₂	.047
	Ar + 2% CO ₂	.047
	Ar + 8% CO ₂	.047
Silicon bronze (CuSi3)	Ar	.040 .047
	Ar + 1% O ₂	.040 .047

*) Only for Mig 4000i, 4001i, 4502c, 5000i, 5002c, 6502c

U8₂ Plus - MIG/MAG welding with SHORT-/SPRAYARC

Wire type	Shielding gas	Wire diameter (inch)
Low alloy or unalloyed wire (Fe)	CO ₂	.030 .035 .040 .047 1/16*
	Ar + 18% CO ₂	.030 .035 .040 .047 1/16*
	Ar + 2% O ₂	.030 .035 .040 .047 1/16*
	Ar + 5%O ₂ + 5% CO ₂	.030 .040 .047 1/16*
	Ar + 8% CO ₂	.030 .035 .040 .047 1/16*
	Ar + 23% CO ₂	.030 .040 .047 1/16*
	Ar + 15% CO ₂ + 5%O ₂	.030 .035 .040 .047 1/16*
	Ar + 16% CO ₂	.030 .040 .047 1/16*
	Ar + 25% CO ₂	.030 .035 .040 .047 1/16*
	Ar + 2% CO ₂	.030 .040 .047 1/16*
Ar + 5% O ₂	.040 .047	
Stainless solid wire (Ss)	Ar + 2%O ₂	.030 .040 .047 1/16*
	Ar + 30%He + 1%O ₂	.030 .040 .047 1/16*
	Ar + 2% CO ₂	.030 .035 .040 .047 1/16*
	Ar + 3%CO ₂ + 1%H ₂	.030 .035 .040 .047 1/16*
	Ar + 32%He + 3%CO ₂ + 1% H ₂	.030 .035 .040 .047 1/16*
Stainless duplex wire (Ss Duplex)	Ar + 2% O ₂	.040
	Ar + 30%He +1%O ₂	.040
Magnesium-alloyed aluminium wire (AlMg)	Ar	.035 .040 .047 1/16*
Silicon-alloyed aluminium wire (AlSi)	Ar	.035 .040 .047 1/16*
	Ar + 50% He	.035 .040 .047 1/16*
Metal powder cored wire (Fe)	Ar + 18% CO ₂	.040 .047 1.4* 1/16*
	Ar+ 8% CO ₂	.040 .047 1.4* 1/16*
Rutile flux cored wire (Fe)	CO ₂	.047 1.4* 1/16*
	Ar + 18% CO ₂	.047 1.4* 1/16*
Basic flux cored wire (Fe)	CO ₂	.040 .047 1.4* 1/16*
	Ar + 18% CO ₂	.040 .047 1.4* 1/16*
	SELF-SHIELDING	.047 1/16*
Stainless flux cored wire (Ss)	Ar + 18% CO ₂	.047
	Ar+ 8% CO ₂	.047
	SELF-SHIELDING	1/16* .094*
Duplex rutile flux cored wire (Ss)	Ar + 18% CO ₂	.047
Metal powder cored stainless wire (Ss)	Ar + 8% CO ₂	.047
	Ar + 2% O ₂	.047
	Ar + 18% CO ₂	.047
	Ar + 2% CO ₂	.047
Nickel base	Ar + 50% He	.035
Silicon bronze (CuSi3)	Ar + 1%O ₂	.040 .047
	Ar	.040 .047
Copper and aluminum wire (CuAl8)	Ar	.040 .047
	Ar + 1%O ₂	.040 .047

*) Only for Mig 4000i, 4001i, 4502c, 5000i, 5002c, 6502c

U8₂ Plus - MIG/MAG welding with PULSE

Wire type	Shielding gas	Wire diameter (inch)
Low alloy or unalloyed wire (Fe)	Ar + 18% CO ₂	.030 .035 .040 .047 1/16*
	Ar + 2% O ₂	.030 .035 .040 .047 1/16*
	Ar + 2% CO ₂	.030 .040 .047 1. 6*
	Ar + 5%O ₂ + 5% CO ₂	.030 .035 .040 .047 1/16*
	Ar + 8% CO ₂	.030 .035 .040 .047 1. 6*
	Ar + 23% CO ₂	.030 .040 .047 1/16*
	Ar +16% CO ₂	.030 .040 .047 1/16*
	Ar + 25% CO ₂	.035
	Ar + 5%O ₂	.040 .047
Stainless wire (Ss)	Ar + 2%O ₂	.030 .035 .040 .047 1/16*
	Ar + 30%He + 1%O ₂	.030 .035 .040 .047 1/16*
	Ar + 2% CO ₂	.030 .035 .040 .047 1/16*
	Ar + 3% CO ₂ + 1%H ₂	.030 .035 .040 .047 1/16
	Ar + 32%He + 3%CO ₂ + 1% H ₂	.030 .035 .040 .047 1/16
Stainless duplex wire (Ss Duplex)	Ar + 30%He + 1%O ₂	.040
	Ar + 2%O ₂	.040
Magnesium-alloyed aluminium wire (AlMg)	Ar	.030 .035 .040 .047 1/16*
	Ar + 50%He	.047
Silicon-alloyed aluminium wire (AlSi)	Ar	.035 .040 .047 1/16*
	Ar + 50% He	.035 .040 .047 1/16*
Metal powder cored wire (Fe)	Ar + 18% CO ₂	.040 .047 .052* 1/16*
	Ar + 8% CO ₂	.040 .047 .052* 1/16*
Metal powder cored stainless wire (Ss)	Ar + 2% O ₂	.047
	Ar + 2% CO ₂	.047
	Ar + 8% CO ₂	.047
Nickel base	Ar	.040 .047
	Ar + 50% He	.035 .040 .047
	Ar + 30% He + 2%H ₂	.040
	Ar + 30% He + 0.5%CO ₂	.040
Silicon bronze (CuSi3)	Ar + 1% O ₂	.040 .047
	Ar	.040 .047
Stainless wire (13964)	Ar + 8%O ₂	.040LOW .040HIGH
Copper and aluminum wire (CuAl8)	Ar	.040 .047
	Ar + 1%O ₂	.040 .047

*) Only for Mig 4000i, 4001i, 4502c, 5000i, 5002c, 6502c

MMA welding

Electrode type	Electrode diameter (inch)
Basic	1/16 5/64 .098 1/8 5/32 .177 3/16 .220* 1/4*
Rutile	1/16 5/64 .098 1/8 5/32 .177 3/16 .220* 1/4* .276*
Cellulose	.098 1/8

*) Only for Mig 4000i, 4001i, 5000i

Carbon, arc air

Electrode diameters (inch) 5/32 3/16 1/4 .316 .394 .512

U8₂

Ordering number





Ordering no.	Denomination
0460 820 880	Control panel Aristo™ U8 ₂ *
0460 820 881	Control panel Aristo™ U8 ₂ Plus *
0460 820 882	Control panel Aristo™ U8 ₂ Plus I/O *
0460 896 070	Instruction manual SE
0460 896 071	Instruction manual DK
0460 896 072	Instruction manual NO
0460 896 073	Instruction manual FI
0460 896 074	Instruction manual GB
0460 896 075	Instruction manual DE
0460 896 076	Instruction manual FR
0460 896 077	Instruction manual NL
0460 896 078	Instruction manual ES
0460 896 079	Instruction manual IT
0460 896 080	Instruction manual PT
0460 896 081	Instruction manual GR
0460 896 082	Instruction manual PL
0460 896 083	Instruction manual HU
0460 896 084	Instruction manual CZ
0460 896 085	Instruction manual SK
0460 896 086	Instruction manual RU
0460 896 087	Instruction manual US
0460 896 089	Instruction manual EE
0460 896 090	Instruction manual LV
0460 896 091	Instruction manual SI
0460 896 092	Instruction manual LT
0460 896 093	Instruction manual CN
0459 839 037	Spare parts list

* For functional differences, see page 82

The instruction manuals are available on the Internet at www.esab.com.

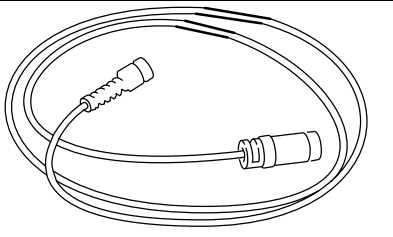
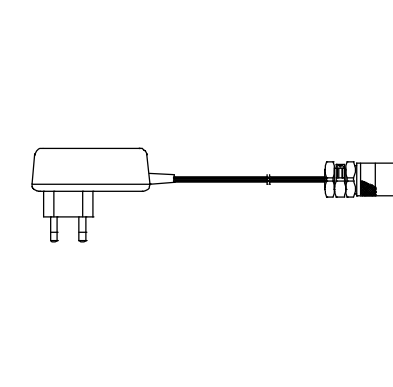
Accessories

	<p>Extension cable (connectors included) 24.6 ft 12-poles 0460 877 891</p>
	<p>Adapter set 230 V AC / 12 V DC, for control box ... 0457 043 880 (for training with the control box disconnected from the machine).</p>
	<p>USB Memory stick Gb 2 0462 062 001</p>

**ESAB Welding & Cutting Products, Florence, SC Welding Equipment
COMMUNICATION GUIDE - CUSTOMER SERVICES**

A	CUSTOMER SERVICE QUESTIONS: Telephone: (800) 362-7080 / Fax: (800) 634-7548 Order Entry Product Availability Pricing Order Information Returns	Hours: 8.00 AM to 7:00 PM EST
B	ENGINEERING SERVICE: Telephone: (834) 664-4416 / Fax: (800) 446-5693 Warranty Returns Authorized Repair Stations Welding Equipment Troubleshooting	Hours: 7.30 AM to 5:00 PM EST
C	TECHNICAL SERVICE: Telephone: (800) ESAB-123 / Fax: (843) 664-4452 Part Numbers Technical Applications Specifications Equipment Recommendations	Hours: 8.00 AM to 5:00 PM EST
D	LITERATURE REQUESTS: Telephone: (843) 664-5562 / Fax: (843) 664-5548	Hours: 7.30 AM to 4:00 PM EST
E	WELDING EQUIPMENT REPAIRS: Telephone: (843) 664-4487 / Fax: (843) 664-5557 Repair Estimates Repair Status	Hours: 7.30 AM to 3:30 PM EST
F	WELDING EQUIPMENT TRAINING: Telephone: (843) 664-4428 / Fax: (843) 679-5864 Training School Information and Registrations	Hours: 7.30 AM to 4:00 PM EST
G	WELDING PROCESS ASSISTANCE: Telephone: (800) ESAB-123	Hours: 7.30 AM to 4:00 PM EST
H	TECHNICAL ASST. CONSUMABLES: Telephone: (800) 933-7070	Hours: 7.30 AM to 5:00 PM EST

IF YOU DO NOT KNOW WHOM TO CALL

Telephone: (800) ESAB-123
Fax: (843) 664-4452
Hours: 7:30 AM to 5:00 PM EST

or

visit us on the web at <http://www.esabna.com>

The ESAB web site offers:
Comprehensive Product Information
Material Safety Data Sheets
Warranty Registration
Instruction Literature Download Library
Distributor Locator
Global Company Information
Press Releases
Customer Feedback & Support

100802



ESAB Welding & Cutting Products
PO BOX 100545, Florence SC 29501-0545